



## ENCLOSURE *A1*

**ENCLOSURE A1** THE PERFECT COMPANION FOR YOUR BAMBU A1! IT PROTECTS YOUR PRINTER FROM DUST AND HUMIDITY, KEEPS YOUR FILAMENTS IN TOP CONDITION WITH PASSIVE DRYING, AND HELPS YOU HEAT THE PRINT CHAMBER FOR EVEN BETTER RESULTS.

### IT'S HERE!

DESIGNED TO SEAMLESSLY INTEGRATE WITH THE AMS ON TOP AND THE **POLYDRYER** IN THE BACK, THIS ENCLOSURE TAKES YOUR BAMBU A1 EXPERIENCE TO THE NEXT LEVEL.

IT FEATURES AIRTIGHT SIDE SPOOL BOXES FOR FILAMENT DRYING, BUILT-IN NFC READER MOUNTS, AND DEDICATED SPACE FOR EXTERNAL SPOOLS. IT'S THE ULTIMATE UPGRADE!

- ✓ FULLY PRINTABLE WITH YOUR BAMBU A1 (EXCEPT GRASS PANELS)
- ✓ QUICK REMOVAL WITH TOP-MOUNTED HOOKS
- ✓ DUAL AIR DUCTS FOR HEAT AND HUMIDITY CONTROL
- ✓ FAN-READY AIR INTAKES FOR OPTIMAL COOLING OF YOUR PRINTER'S ELECTRONICS
- ✓ EASY ACCESS TO FILAMENTS AND PTFE TUBE SUPPORT

WANT VENTILATION HOLES WITH CARBON FILTERS?  
CUSTOM OPTIONS AVAILABLE UPON REQUEST!

## A1 Drawer Standar Enclosure Dimensions

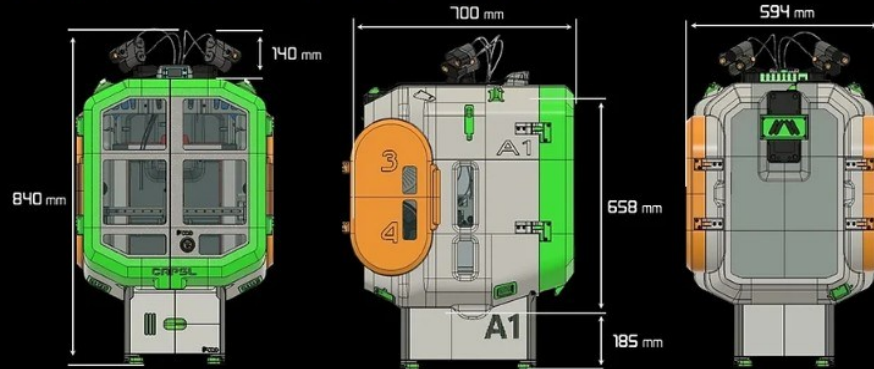

## Dimensions with Doors Open

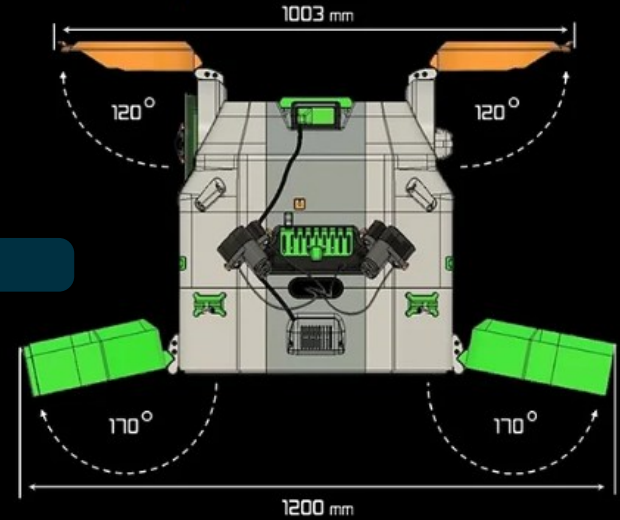

[WWW.CC3DPROJECTS.COM](http://WWW.CC3DPROJECTS.COM)

## A1 Drawer Lower Edition Enclosure Dimensions

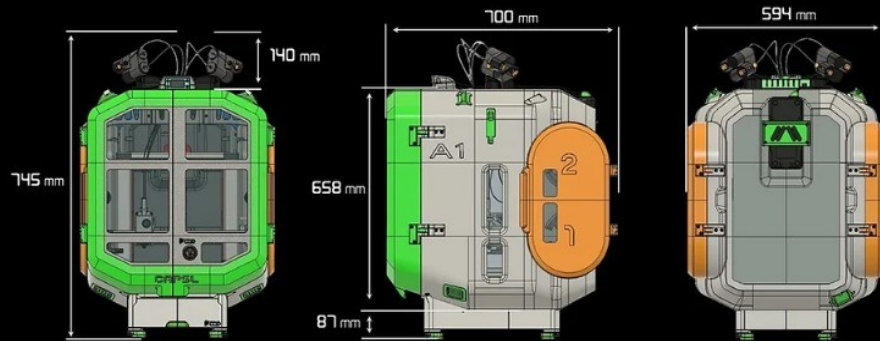

## Print time and filaments needed.

The table below shows the required filament amounts based on the color combination I used, along with the estimated print times calculated at standard print speed.

PART	PRINT TIME	PETG	PETG	PETG	PETG	PETG	PETG	PETG	TPU 95A
LEFT SIDE	4D 19H	2.4 KG							
RIGHT SIDE	4D 2H	2.2 KG							
TOP SIDE	1D 21H	1.0 KG							
BACK SIDE	1D 21H		0.8 KG						
SPOOL DOORS	2D 1H			1.0 KG					
FRONT DOORS	2D		0.4 KG	1.2 KG					
DRYER PIPES	23H					0.2 KG	0.4 KG		
ACCESSORIES/EXTRA	1D 2H	0.2 KG		0.5 KG		0.05 KG		0.2 KG	

WWW.CC3DPROJECTS.COM

## REQUIRED SPARE PARTS:



SCREW M4 14 mm

250 units



MAGNET 8X2 mm

78 units



PC4 - M10

8 units



Adhesive GASKET

4 m



POLYDRYER

1 unit

## FOLLOW THESE SIMPLE TIPS AND YOU'RE GOLDEN:



### 1. STICK WITH REGULAR PETG

USE STANDARD PETG, AND SKIP THE HIGH FLOW (HF) STUFF. HF MIGHT SOUND COOL, BUT IT CAN'T HANDLE HEAT AS WELL, AND THAT CAN MESS WITH YOUR PRINT'S DURABILITY. YEAH, REGULAR PETG IS SHINIER — I GET IT — BUT HERE'S A TRICK: SPRAY IT WITH A MATTE CLEAR COAT LIKE I DID. BOOM! PROBLEM SOLVED.



### 2. DON'T USE PLA FOR SUPPORTS

VOID USING PLA AS SUPPORT MATERIAL. SERIOUSLY. EVEN IF YOU SWITCH FILAMENTS, LEFTOVER PLA IN THE NOZZLE CAN MESS WITH LAYER ADHESION, AND THAT'S NO FUN. AND DON'T STRESS — THE SUPPORTS COME OFF EASY, I PROMISE. YOU GOT THIS.



### 3. KEEP IT SLOW AND STEADY

RESIST THE URGE TO CRANK UP THE PRINT SPEED. GOING TOO FAST CAN LEAD TO WEIRD-LOOKING CORNERS AND WARPED PARTS. STICK TO STANDARD SPEED — YOUR PRINT WILL THANK YOU.



### 4. USE A GRIPPY PRINT BED

THESE PARTS ARE ON THE BIGGER SIDE, SO BED ADHESION IS EVERYTHING. MAKE SURE YOUR BUILD PLATE'S GOT A GOOD GRIP TO AVOID WARPING OR LIFTING. TRUST ME, A SOLID FIRST LAYER MAKES ALL THE DIFFERENCE.

[WWW.CC3DPROJECTS.COM](http://WWW.CC3DPROJECTS.COM)



### PRINT TIMES FOR EACH PART

PART	PRINT TIME
LEFT SIDE	4 DAYS 19 HOURS
RIGHT SIDE	4 DAYS 2 HOURS
TOP	1 DAY 21 HOURS
BACK	1 DAY 11 HOURS
SPOOL DOORS	2 DAYS 1 HOUR
ACCESSORIES	2 DAYS 15 HOURS

Buy me a coffee





# LEFT SIDE PANEL

MAKE SURE ALL PARTS AND CONNECTION POINTS ARE CLEAN AND FREE FROM ANY DEBRIS OR LEFTOVER BITS. EVERYTHING SHOULD FIT TOGETHER NICE AND SMOOTH—NO ROUGH EDGES ALLOWED!  
MATCH THE PIECES JUST LIKE IN THE PICTURE AND SECURE THEM BY INSERTING AND TIGHTENING THE SCREWS INTO EACH HOLE MARKED IN RED. EASY PEASY!

Buy me a coffee

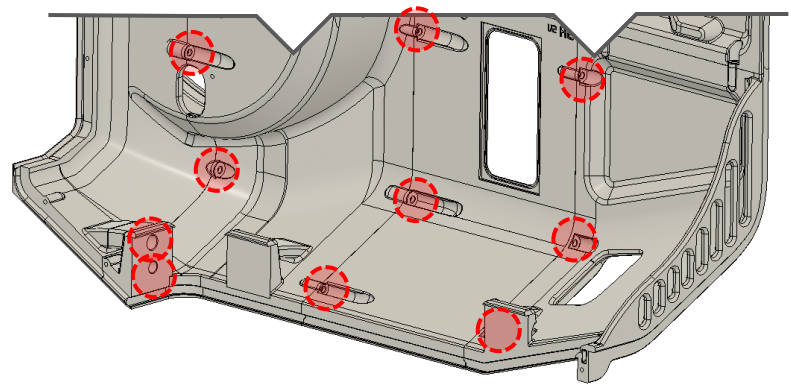
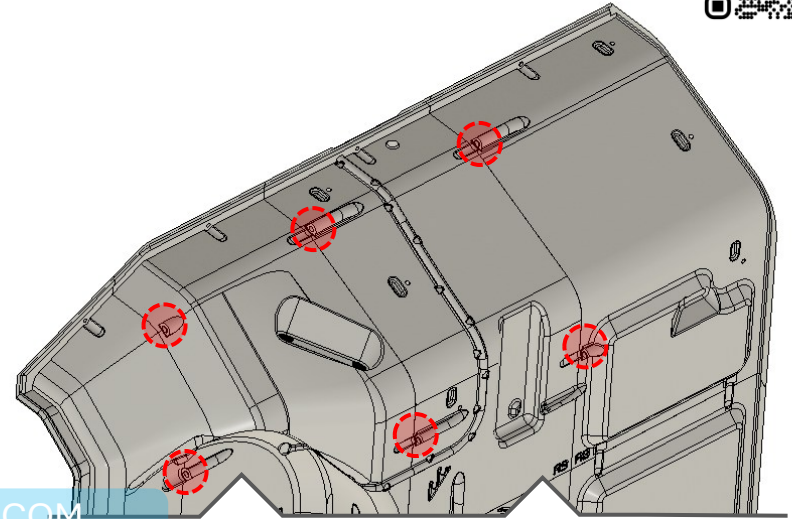
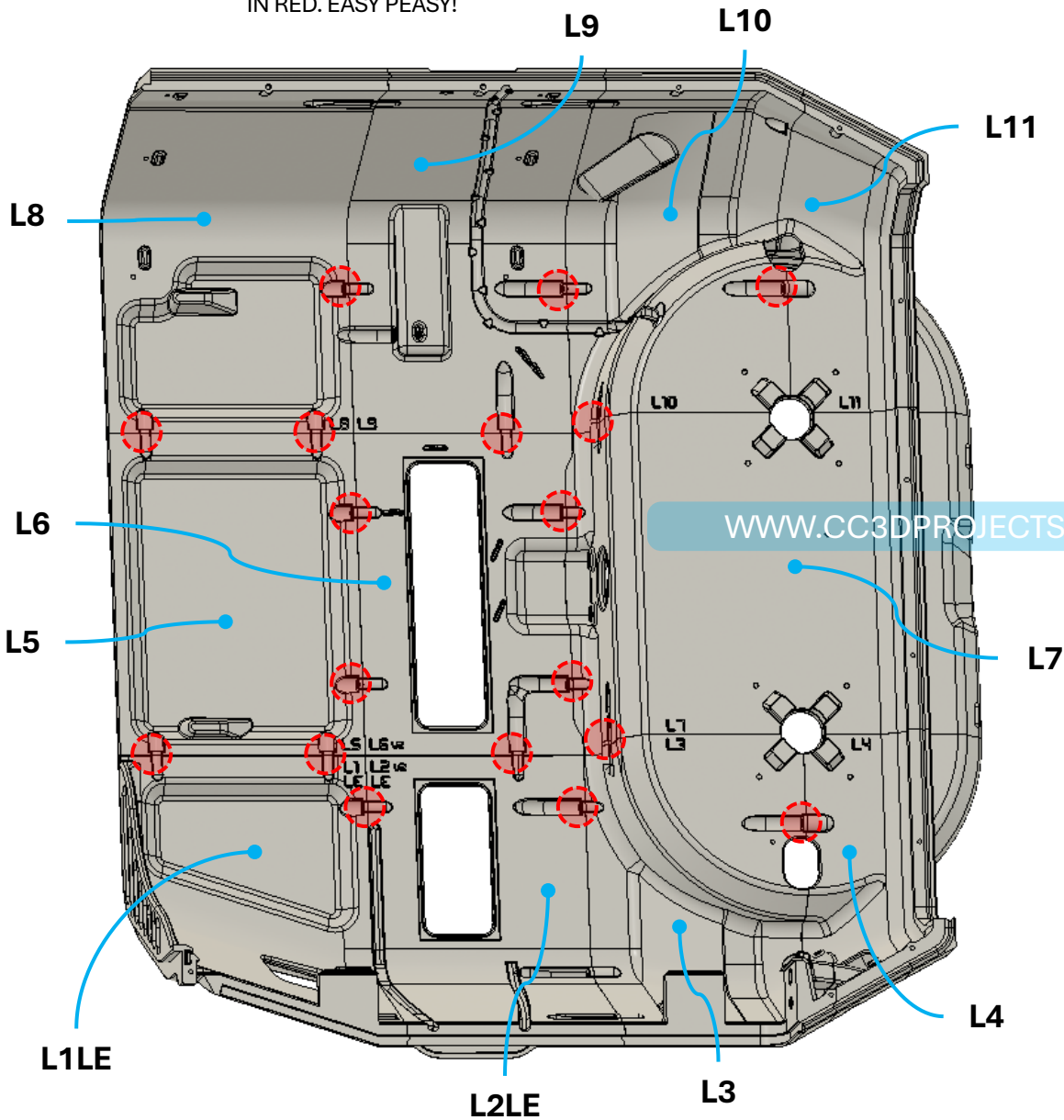

ALL MATERIAL PRODUCED AND PROVIDED HAS BEEN CONCEIVED, AUTHORED AND PRODUCED BY ENRICO MAZZAROL - ALL RIGHTS RESERVED.



# LEFT SIDE PANEL

# ENCLOSURE A1



GRAB YOUR FAST-DRYING GLUE AND STICK ONE MAGNET INTO EACH HOLE MARKED IN PINK. MAKE SURE IT'S NICE AND SNUG!  
NEXT UP, SCREW IN ONE PTFE TUBE FITTING INTO EVERY HOLE MARKED IN GREEN. TWIST 'EM IN TIGHT—THEY'VE GOT WORK TO DO!

FOR THE MAGNETS, USE APPLICATOR **A** IT MAKES THE JOB WAY EASIER AND KEEPS YOUR FINGERS GLUE-FREE.  
*HAVEN'T DOWNLOADED THE MAGNET APPLICATORS YET? NO WORRIES! THEY'RE FREE AND READY FOR YOU ON THIS PAGE*  
[HTTPS://BUYMEACOFFEE.COM/EMAZZAROL/E/343896.](https://buymeacoffee.com/emazzarol/e/343896)

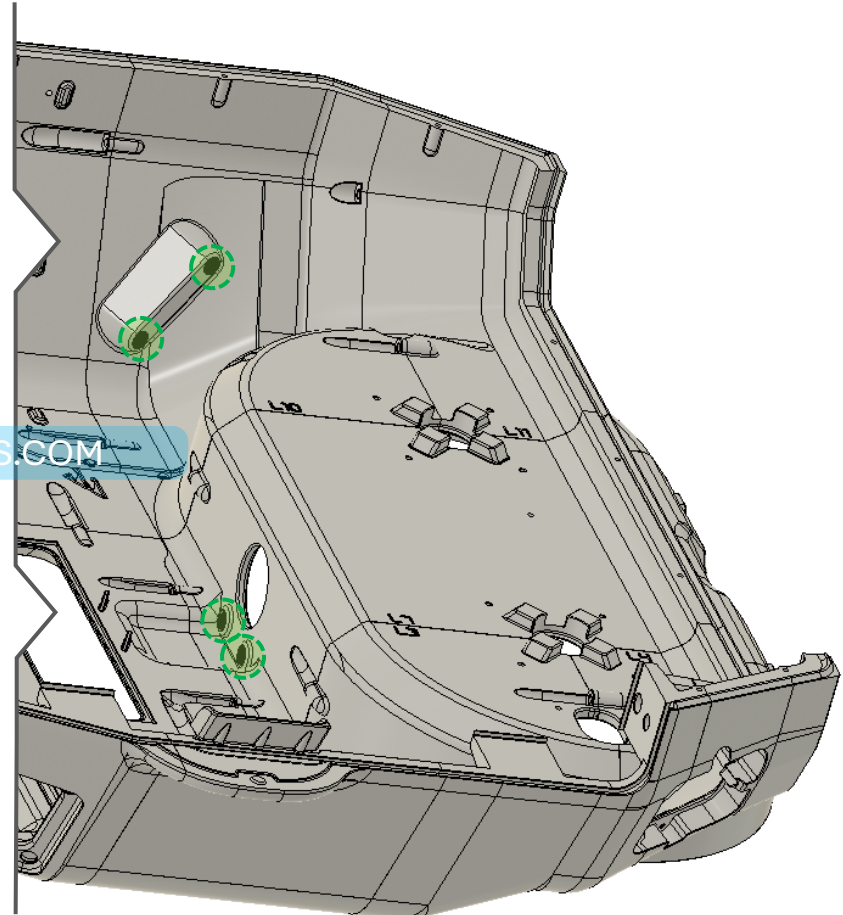
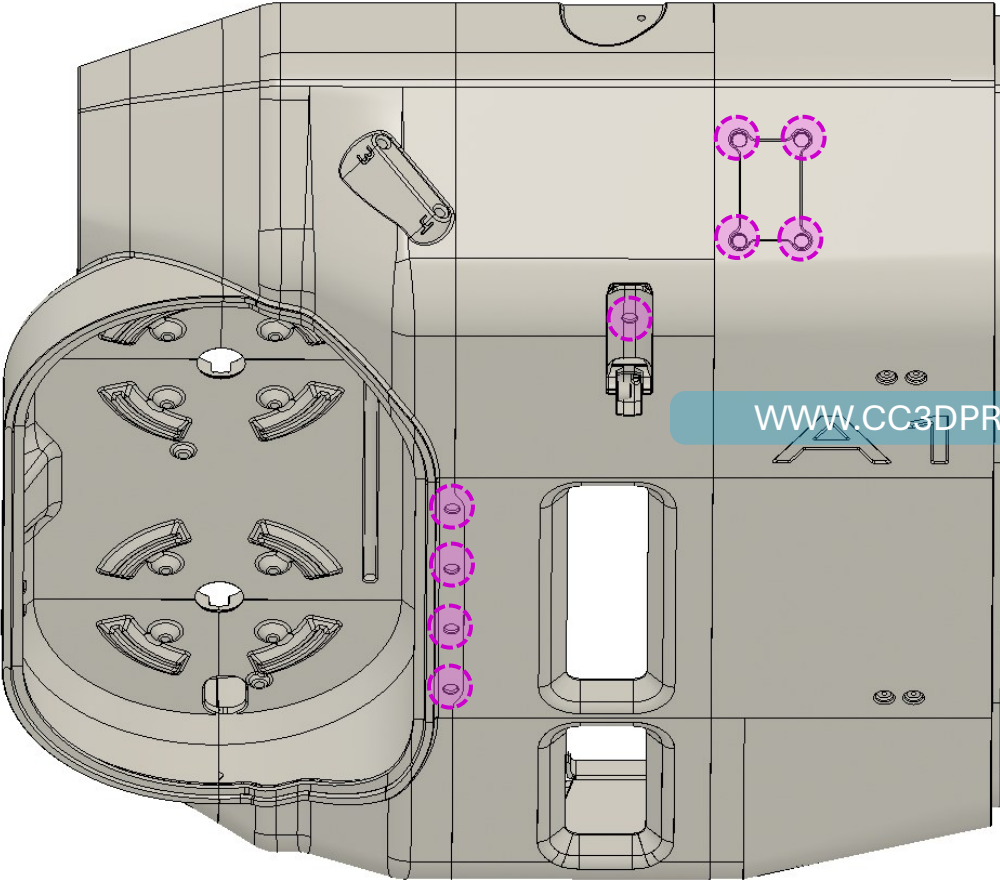

WWW.CC3DPROJECTS.COM

ALL MATERIAL PRODUCED AND PROVIDED HAS BEEN CONCEIVED, AUTHORED AND PRODUCED BY ENRICO MAZZAROL - ALL RIGHTS RESERVED.



# LEFT SIDE PANEL

# ENCLOSURE A1



GRAB YOUR FAST-DRYING GLUE AND STICK ONE MAGNET INTO EACH HOLE MARKED IN PINK. MAKE SURE IT'S NICE AND SNUG!  
FOR THE MAGNETS, USE APPLICATOR **A** IT MAKES THE JOB WAY EASIER AND KEEPS YOUR FINGERS GLUE-FREE.

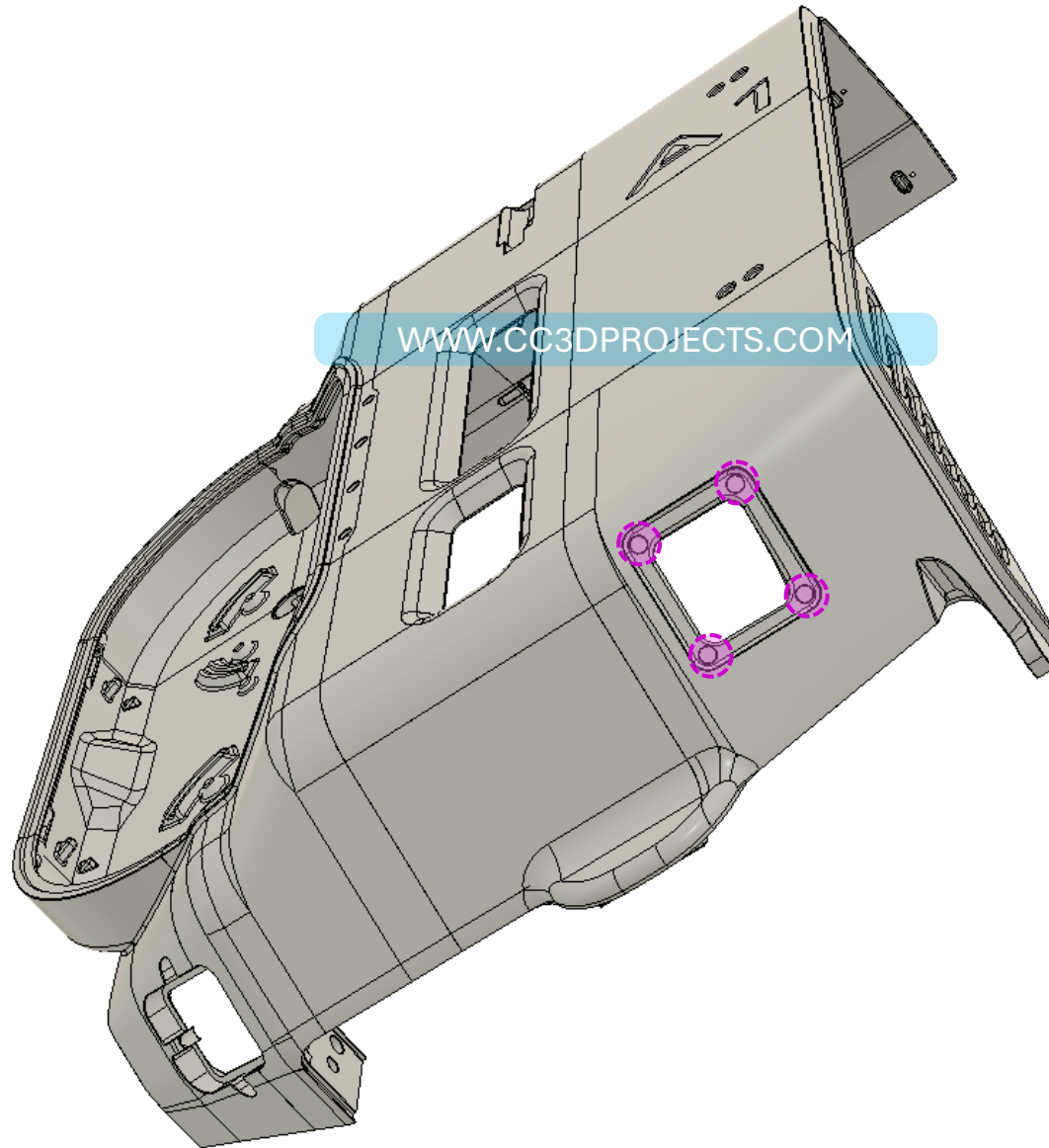

ALL MATERIAL PRODUCED AND PROVIDED HAS BEEN CONCEIVED, AUTHORED AND PRODUCED BY ENRICO MAZZAROL - ALL RIGHTS RESERVED.



# LEFT SIDE PANEL

# ENCLOSURE A1



Buy me a coffee



### TIME TO INSTALL THE LITTLE WALLS FOR THE POOP CHUTE!

FIRST THINGS FIRST—GIVE THE EDGES OF THOSE SMALL PANELS A GOOD CLEAN. THEY NEED TO SLOT PERFECTLY INTO THE STRUCTURE ON THE LEFT SIDE. MOST OF THE TIME, THEY'LL SNAP RIGHT INTO PLACE WITH NO GLUE NEEDED. BUT HEY, IF THEY'RE FEELING A LITTLE LOOSE, GO AHEAD AND ADD A TINY BIT OF GLUE TO KEEP THEM STEADY.

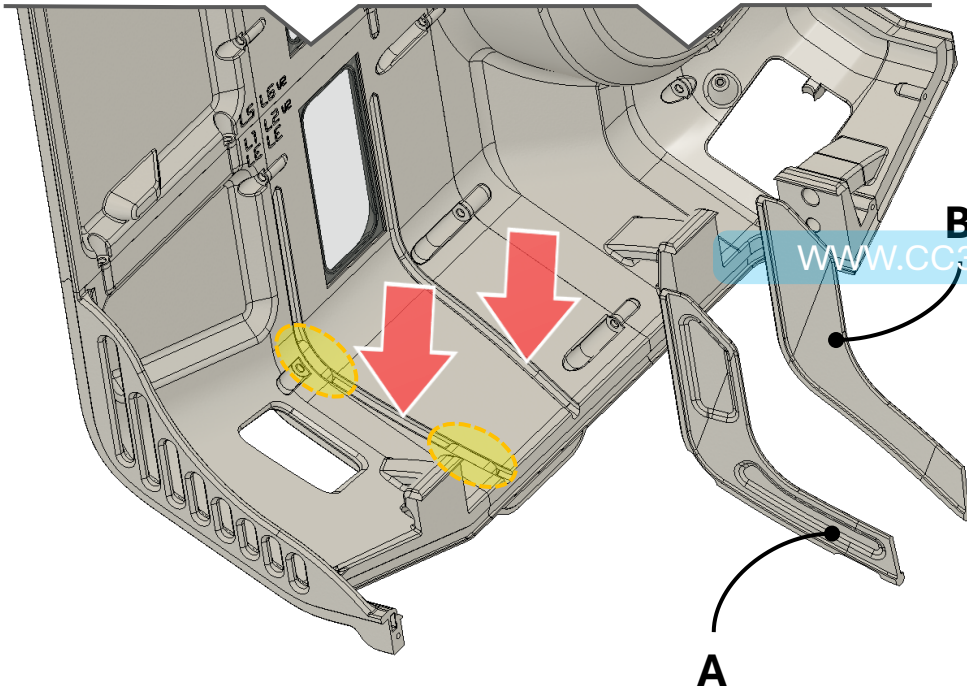
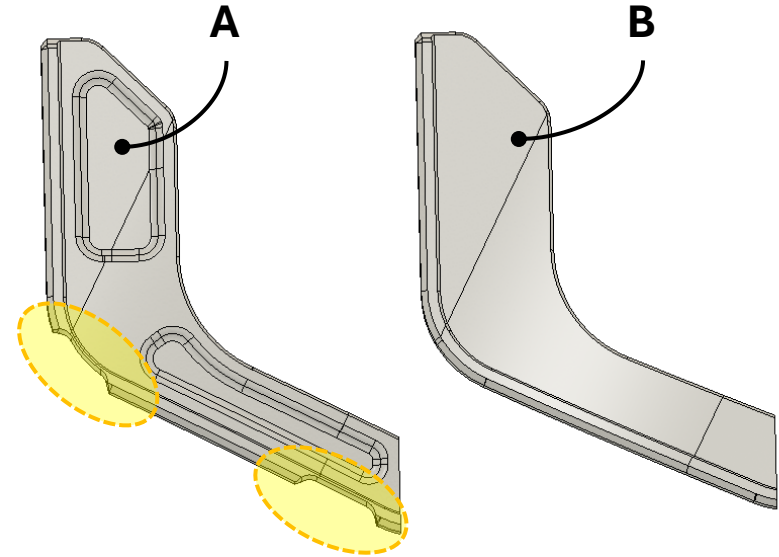

WWW.CC3DPROJECTS.COM

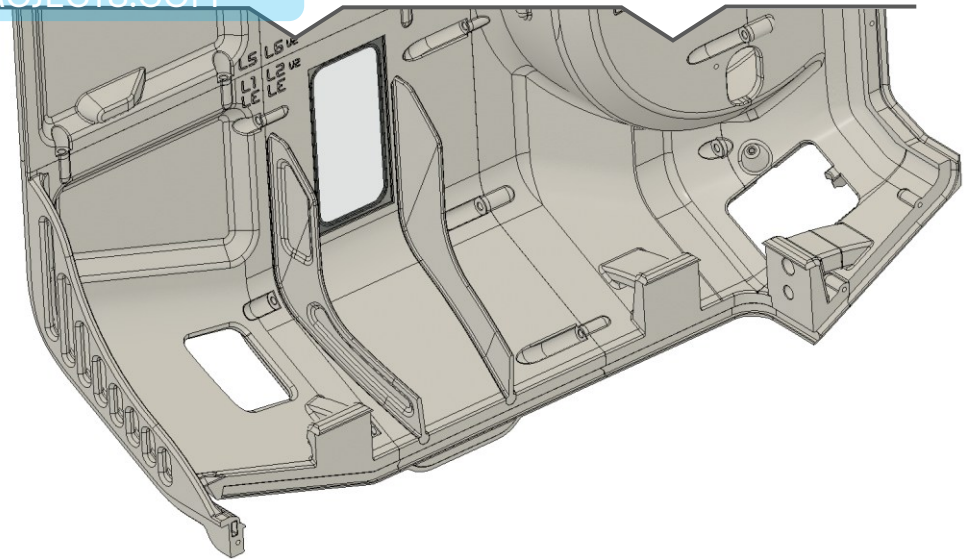

ALL MATERIAL PRODUCED AND PROVIDED HAS BEEN CONCEIVED, AUTHORED AND PRODUCED BY ENRICO MAZZAROL - ALL RIGHTS RESERVED.



# RIGHT SIDE PANEL

MAKE SURE ALL PARTS AND CONNECTION POINTS ARE CLEAN AND FREE FROM ANY DEBRIS OR LEFTOVER BITS. EVERYTHING SHOULD FIT TOGETHER NICE AND SMOOTH—NO ROUGH EDGES ALLOWED!

MATCH THE PIECES JUST LIKE IN THE PICTURE AND SECURE THEM BY INSERTING AND TIGHTENING THE SCREWS INTO EACH HOLE MARKED IN RED. EASY PEASY!

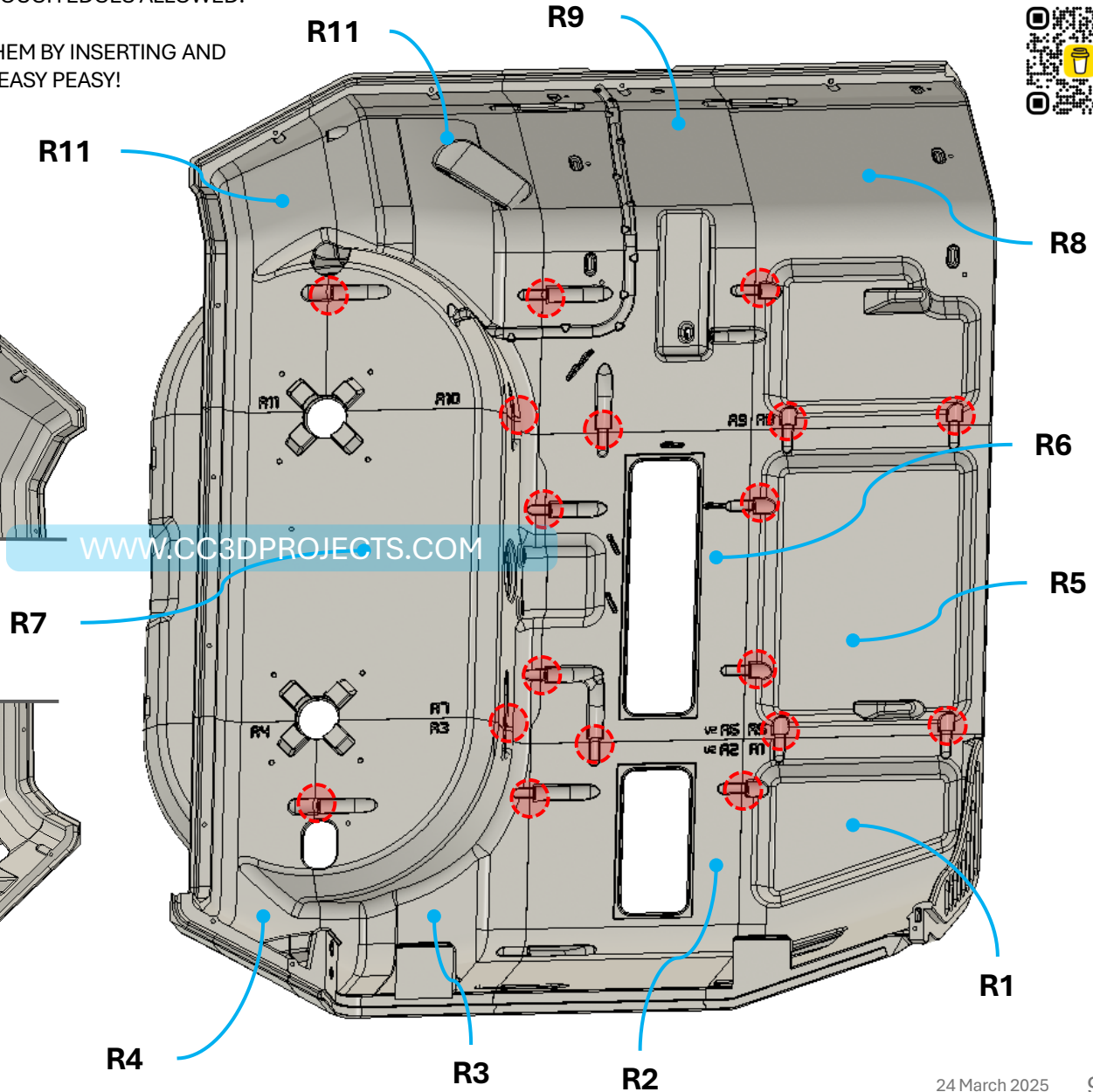
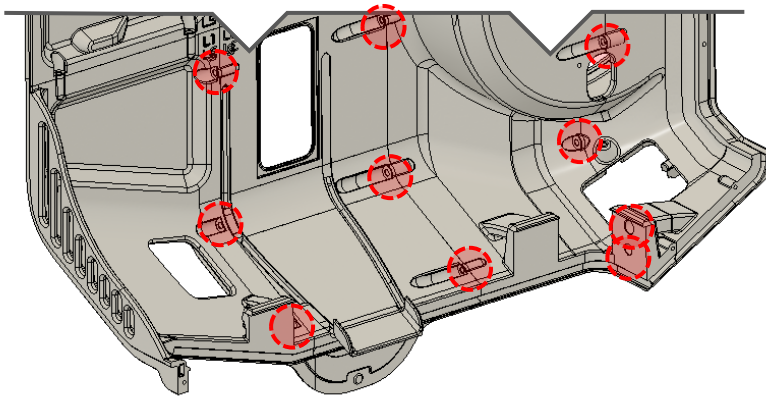
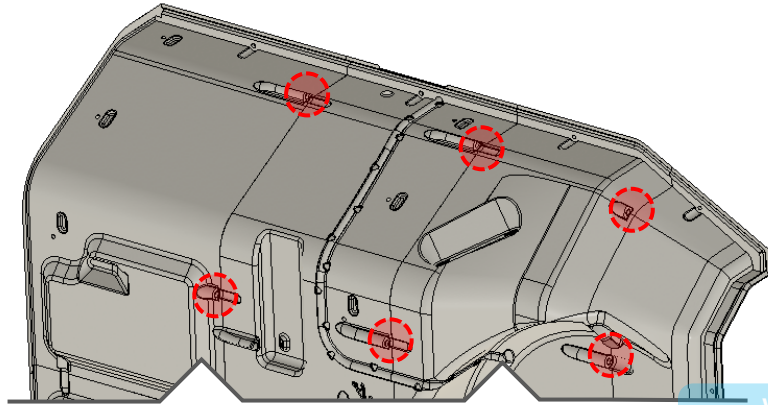

ALL MATERIAL PRODUCED AND PROVIDED HAS BEEN CONCEIVED, AUTHORED AND PRODUCED BY ENRICO MAZZAROL - ALL RIGHTS RESERVED.



# RIGHT SIDE PANEL

# ENCLOSURE A1



GRAB YOUR FAST-DRYING GLUE AND STICK ONE MAGNET INTO EACH HOLE MARKED IN PINK. MAKE SURE IT'S NICE AND SNUG! NEXT UP, SCREW IN ONE PTFE TUBE FITTING INTO EVERY HOLE MARKED IN GREEN. TWIST 'EM IN TIGHT—THEY'VE GOT WORK TO DO!

FOR THE MAGNETS, USE APPLICATOR **A** IT MAKES THE JOB WAY EASIER AND KEEPS YOUR FINGERS GLUE-FREE. *HAVEN'T DOWNLOADED THE MAGNET APPLICATORS YET? NO WORRIES! THEY'RE FREE AND READY FOR YOU ON THIS PAGE [HTTPS://BUYMEACOFFEE.COM/EMAZZAROL/E/343896](https://buymeacoffee.com/emazzarol/e/343896).*

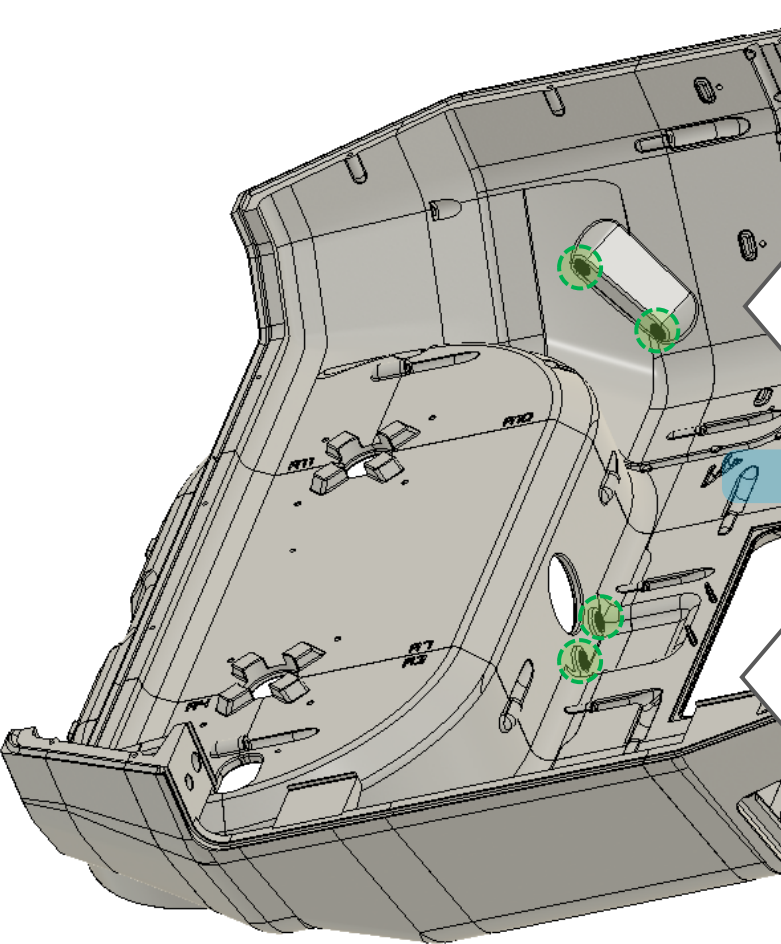

WWW.CC3DPROJECTS.COM

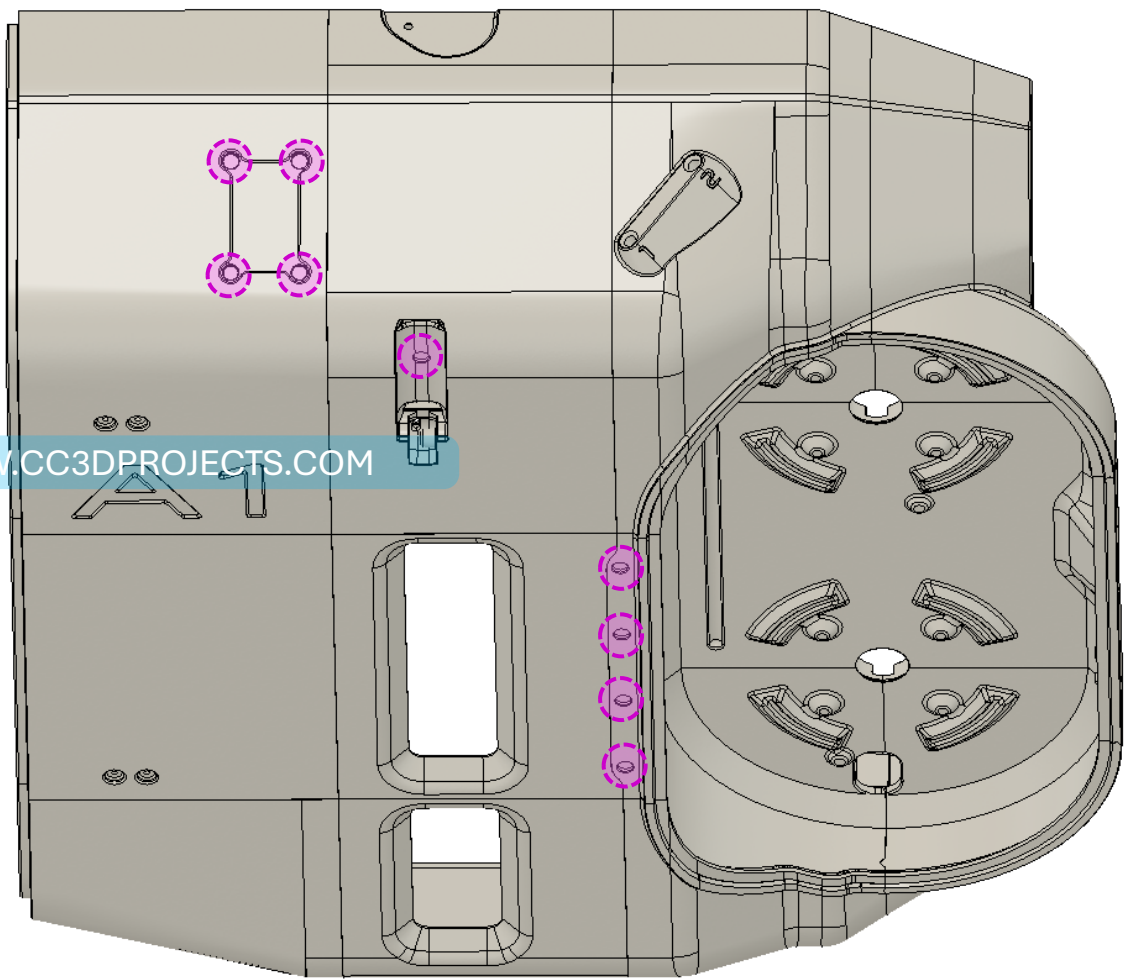

ALL MATERIAL PRODUCED AND PROVIDED HAS BEEN CONCEIVED, AUTHORED AND PRODUCED BY ENRICO MAZZAROL - ALL RIGHTS RESERVED.



# RIGHT SIDE PANEL

GRAB YOUR FAST-DRYING GLUE AND STICK ONE MAGNET INTO EACH HOLE MARKED IN PINK. MAKE SURE IT'S NICE AND SNUG!  
FOR THE MAGNETS, USE APPLICATOR **A** IT MAKES THE JOB WAY EASIER AND KEEPS YOUR FINGERS GLUE-FREE.

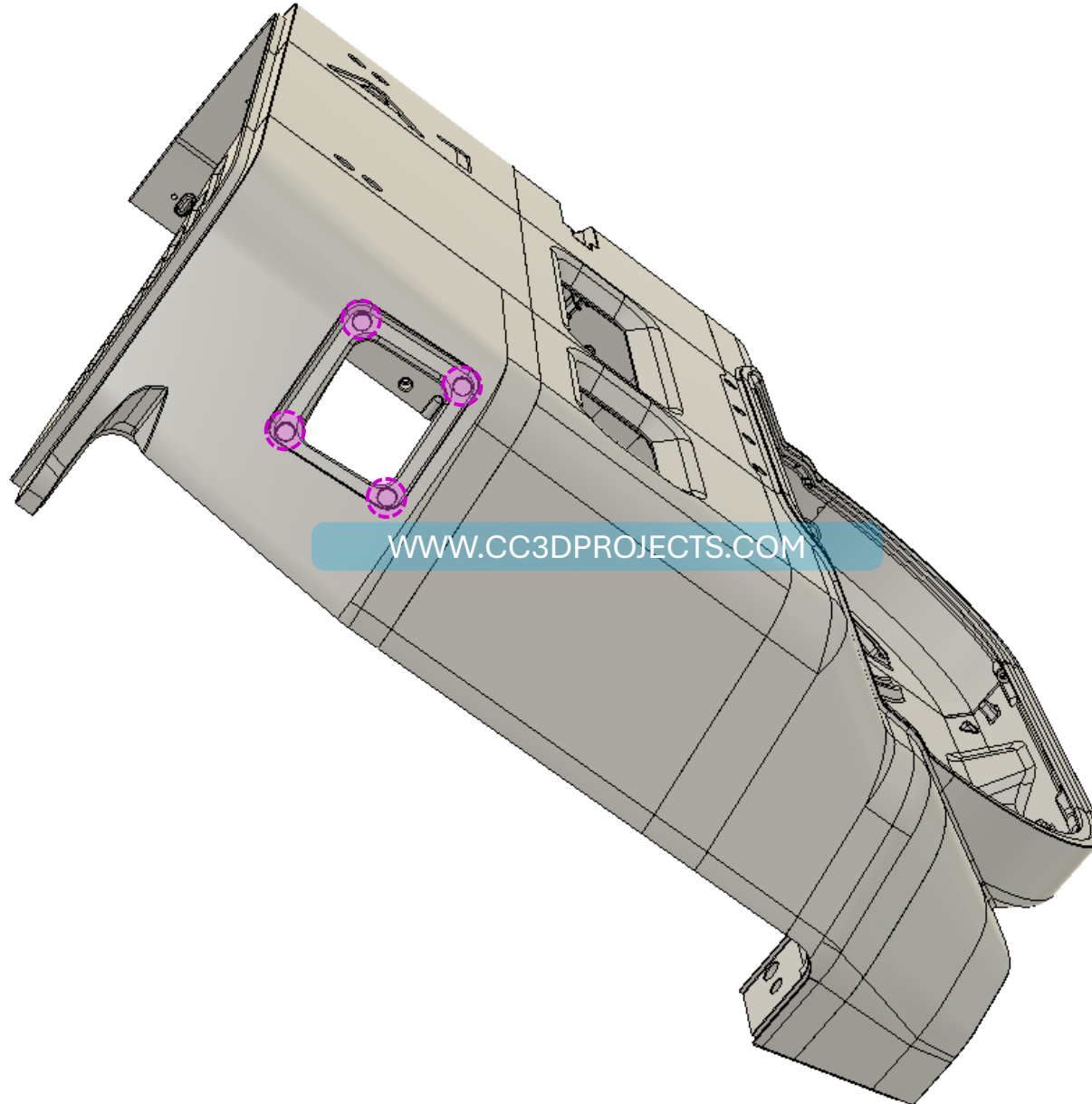

[WWW.CC3DPROJECTS.COM](http://WWW.CC3DPROJECTS.COM)

Buy me a coffee





## TOP SIDE PANEL

## ENCLOSURE A1



### LET'S TALK ABOUT THE TOP!

YOU'VE GOT TWO OPTIONS HERE:

**OPTION A:** WANT TO INSTALL THE EXTERNAL CONTROL PANEL FOR THE DRYER? GO FOR IT!

**OPTION B:** PREFER TO KEEP THE DRYER JUST THE WAY IT CAME FROM THE FACTORY? TOTALLY FINE TOO!

PICK THE SETUP THAT WORKS BEST FOR YOU—EITHER WAY, YOUR BUILD'S LOOKIN' GOOD!

Buy me a coffee

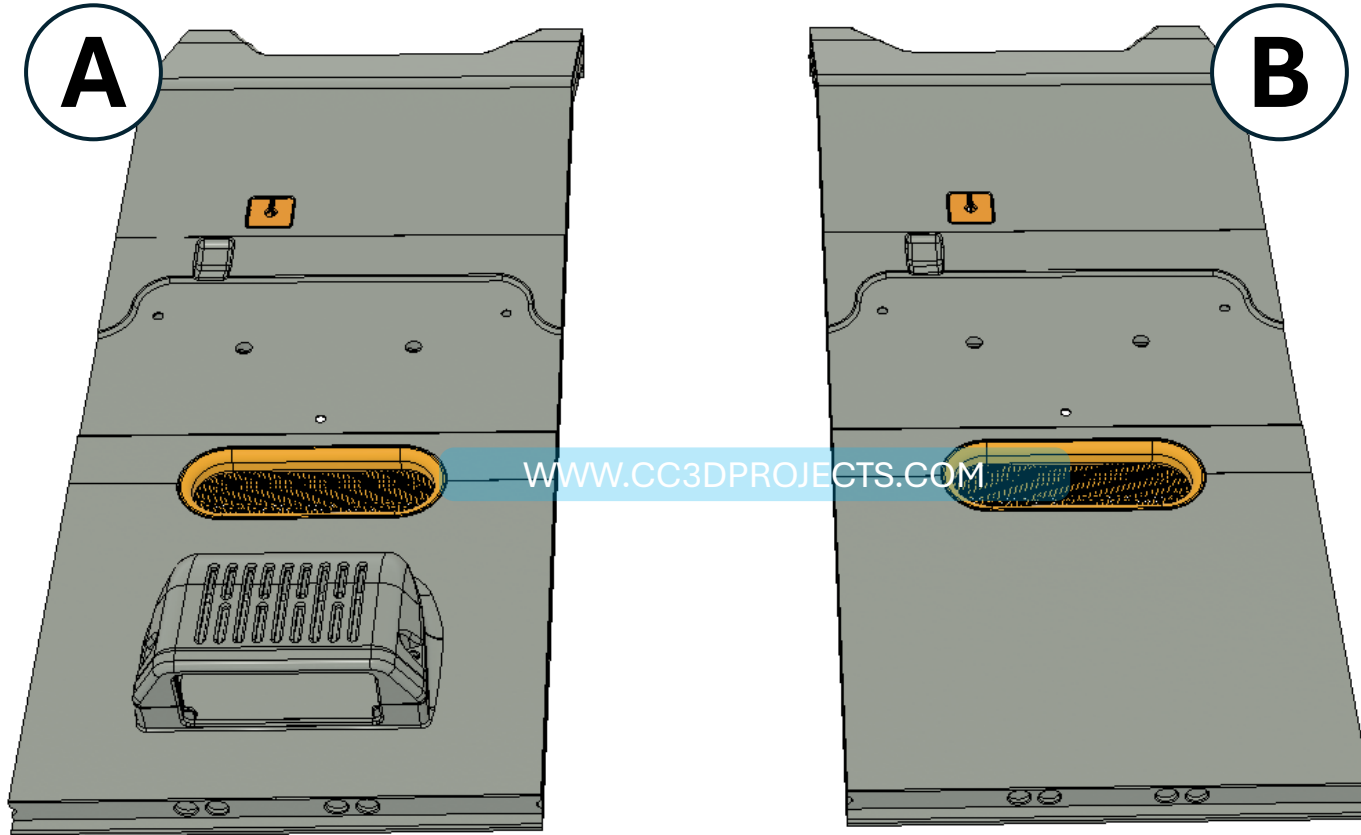



# TOP SIDE PANEL

# ENCLOSURE A1



**READY? LET'S LOCK IT IN!**

ONCE YOU'VE PICKED THE SETUP THAT WORKS FOR YOU, POP THE SCREWS INTO THE HOLES MARKED IN RED AND START ASSEMBLING EVERYTHING TOGETHER.

AND YEP—YOU'LL NEED TO INSTALL MAGNETS HERE TOO, SO GRAB APPLICATOR **A** AND GET THOSE BABIES IN PLACE!

Buy me a coffee



ALL MATERIAL PRODUCED AND PROVIDED HAS BEEN CONCEIVED, AUTHORED AND PRODUCED BY ENRICO MAZZAROL - ALL RIGHTS RESERVED.

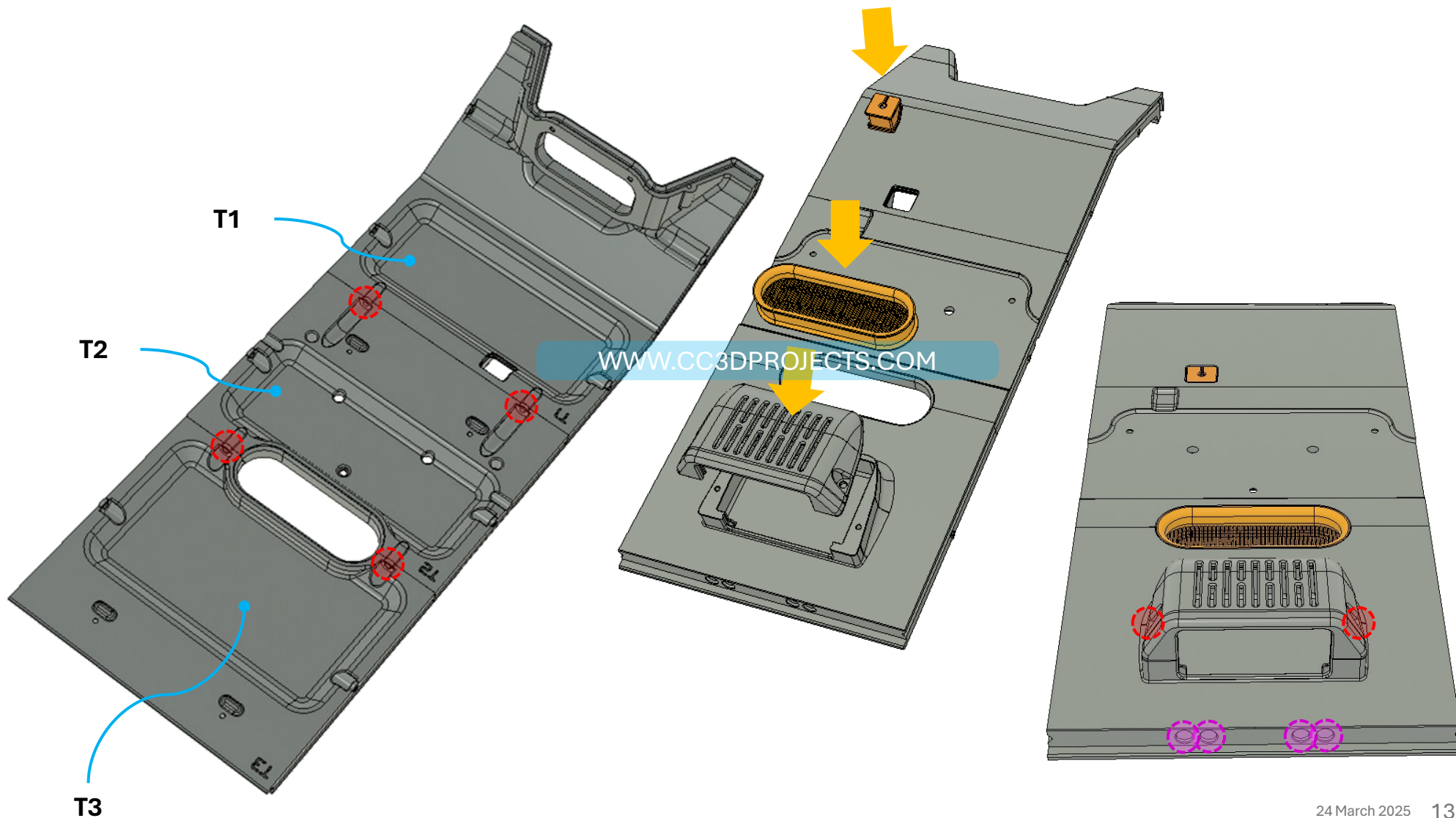



# REINFORCEMENT + AMS ROLLER TUBES

# ENCLOSURE A1



Buy me a coffee



## LET'S START DISASSEMBLING THE AMS LITE!

TIME TO BRING IN THE ALUMINUM TUBES THAT SUPPORT THE SPOOL ROTORS.

FIRST, REMOVE THEM FROM THE AMS UNIT. ONCE THEY'RE OUT, YOU'LL NEED TO CUT EACH TUBE EXACTLY IN HALF. PRO TIP: DON'T FORGET TO ACCOUNT FOR THE WIDTH OF YOUR SAW BLADE SO YOU GET A PERFECTLY CENTERED CUT.

AFTER CUTTING, CLEAN UP ANY BURRS OR SHARP EDGES ON THE ENDS—SMOOTH IS THE WAY TO GO! NOW YOU'RE READY TO ATTACH THEM TO THE X-SHAPED SUPPORTS. THESE WERE DESIGNED FOR A SNUG FIT, SO DON'T BE SHY—GRAB A HAMMER IF NEEDED TO GET THOSE TUBES ALL THE WAY IN.

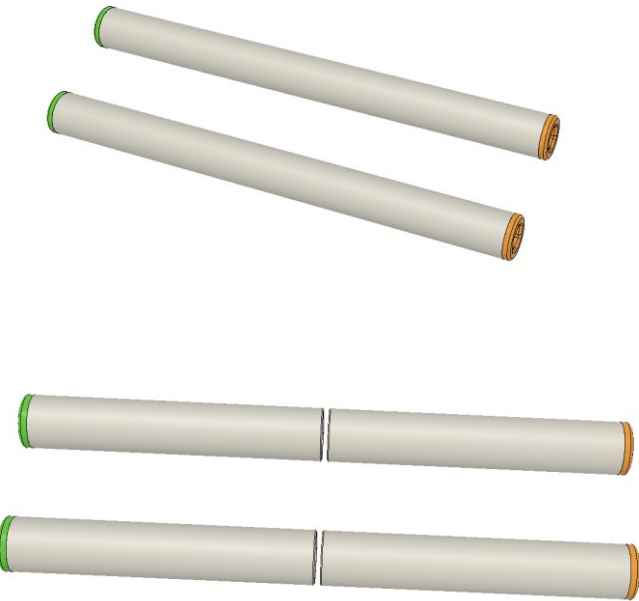

WWW.CC3DPROJECTS.COM

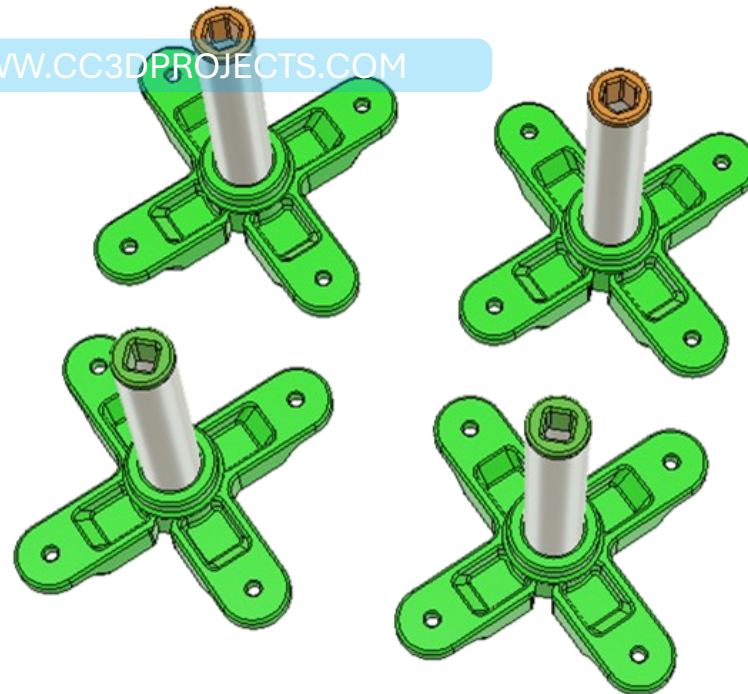

ALL MATERIAL PRODUCED AND PROVIDED HAS BEEN CONCEIVED, AUTHORED AND PRODUCED BY ENRICO MAZZAROL - ALL RIGHTS RESERVED.



# REINFORCEMENT + AMS ROLLER TUBES

# ENCLOSURE A1



Buy me a coffee



**RIGHT SIDE**

**LEFT SIDE**

**PAY ATTENTION TO ORIENTATION!**  
 WHEN PLACING THE X-SUPPORTS ONTO THE STRUCTURE, MAKE SURE YOU FOLLOW THE COLOR-CODED CONFIGURATION—COLORS MATTER HERE!

ALSO, DOUBLE-CHECK THAT THE ARROWS ON THE SUPPORTS ARE POINTING UP. THAT'S THE CORRECT ORIENTATION, AND IT'LL SAVE YOU A HEADACHE LATER ON!

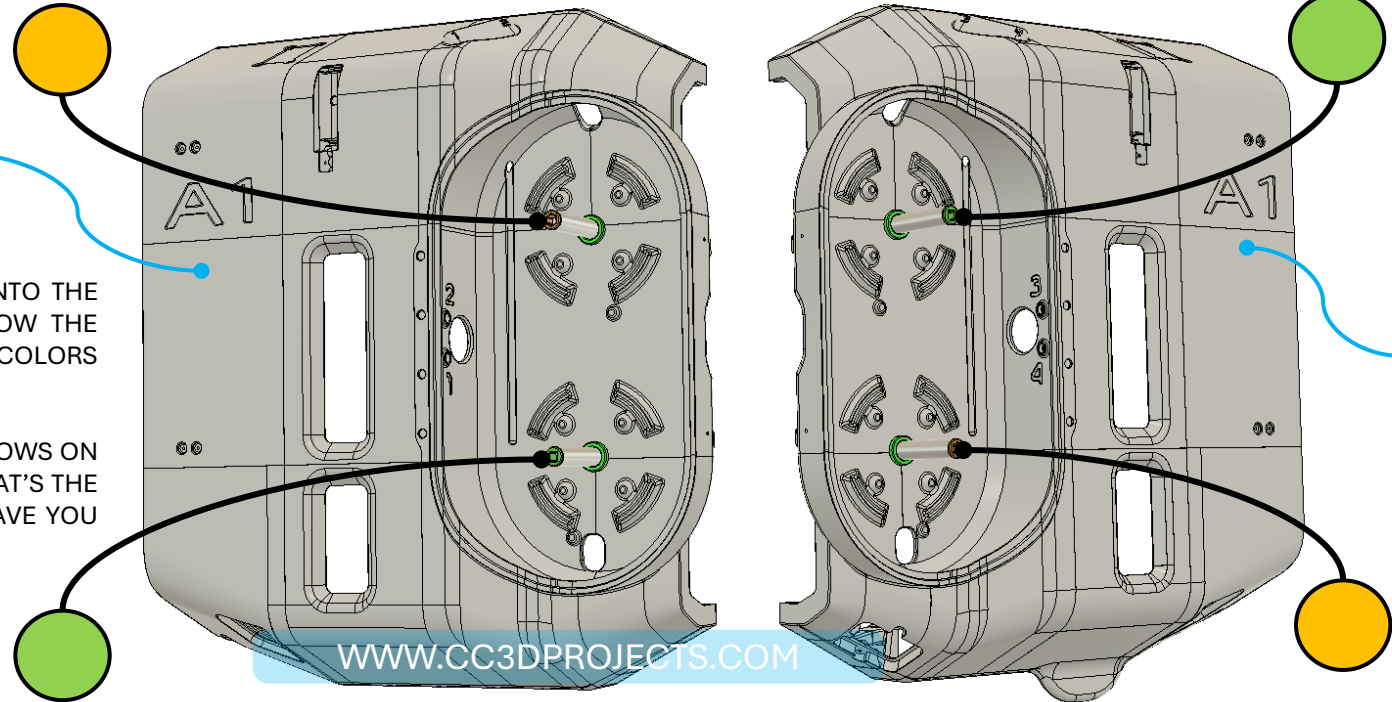

ALL MATERIAL PRODUCED AND PROVIDED HAS BEEN CONCEIVED, AUTHORED AND PRODUCED BY ENRICO MAZZAROL - ALL RIGHTS RESERVED.



# GLASS SIDE PANELS

## TIME TO INSTALL THE SIDE PANEL WINDOWS!

THESE PANELS DON'T HAVE MOCKUPS—BUT NO WORRIES! THEY'RE SIMPLE RECTANGLES, SO JUST GRAB YOUR CALIPER, TAKE THE MEASUREMENTS, AND YOU'RE GOOD TO GO.

FOR THE WINDOWS, I USE 0.6 MM POLYCARBONATE, CUT OUT FROM A PHOTO FRAME (YEP, THE KIND YOU CAN FIND PRETTY MUCH ANYWHERE). I CUT IT WITH A UTILITY KNIFE, NICE AND SLOW, THEN GLUE IT IN PLACE USING TRANSPARENT PHONE SCREEN ADHESIVE. WORKS LIKE A CHARM!

Buy me a coffee

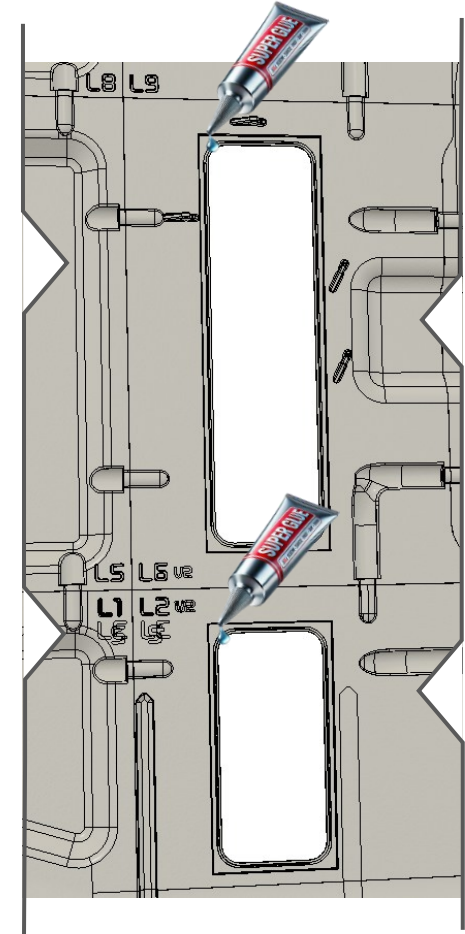
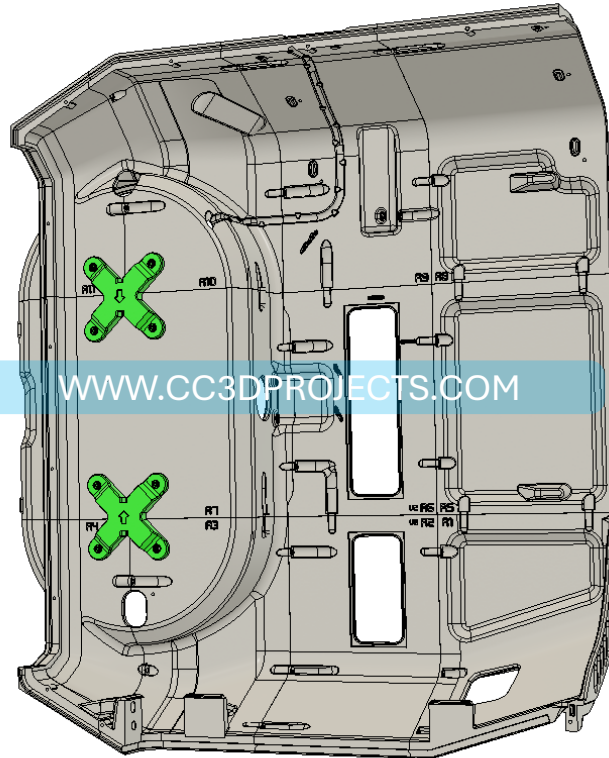
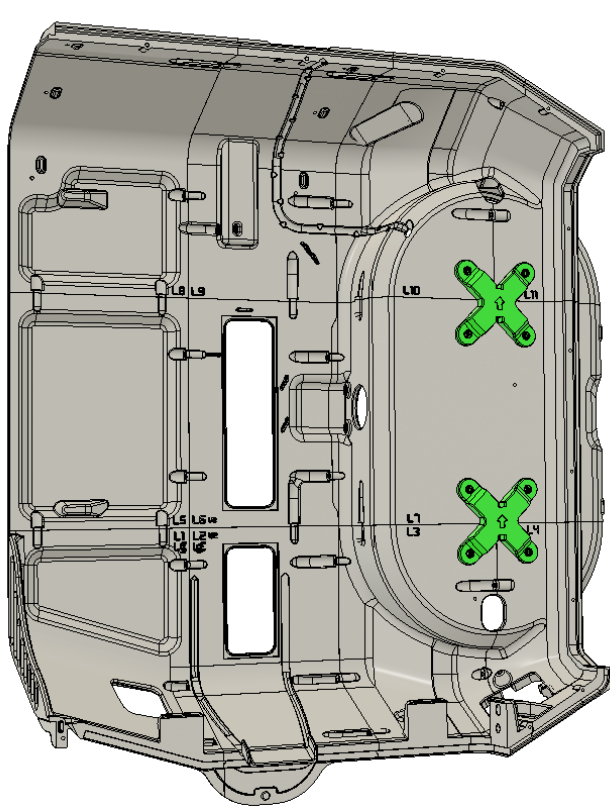



# BACK PANEL ON LEFT PANEL

# ENCLOSURE A1



**LET'S ADD HALF THE BACK PANELS!**

NOW WE'RE GOING TO INSTALL HALF OF THE BACK PANELS ONTO THE LEFT SIDE OF THE ENCLOSURE. AS ALWAYS, JUST POP THE SCREWS INTO THE HOLES MARKED IN RED—AND THAT'S IT, YOU'RE GOOD TO GO!

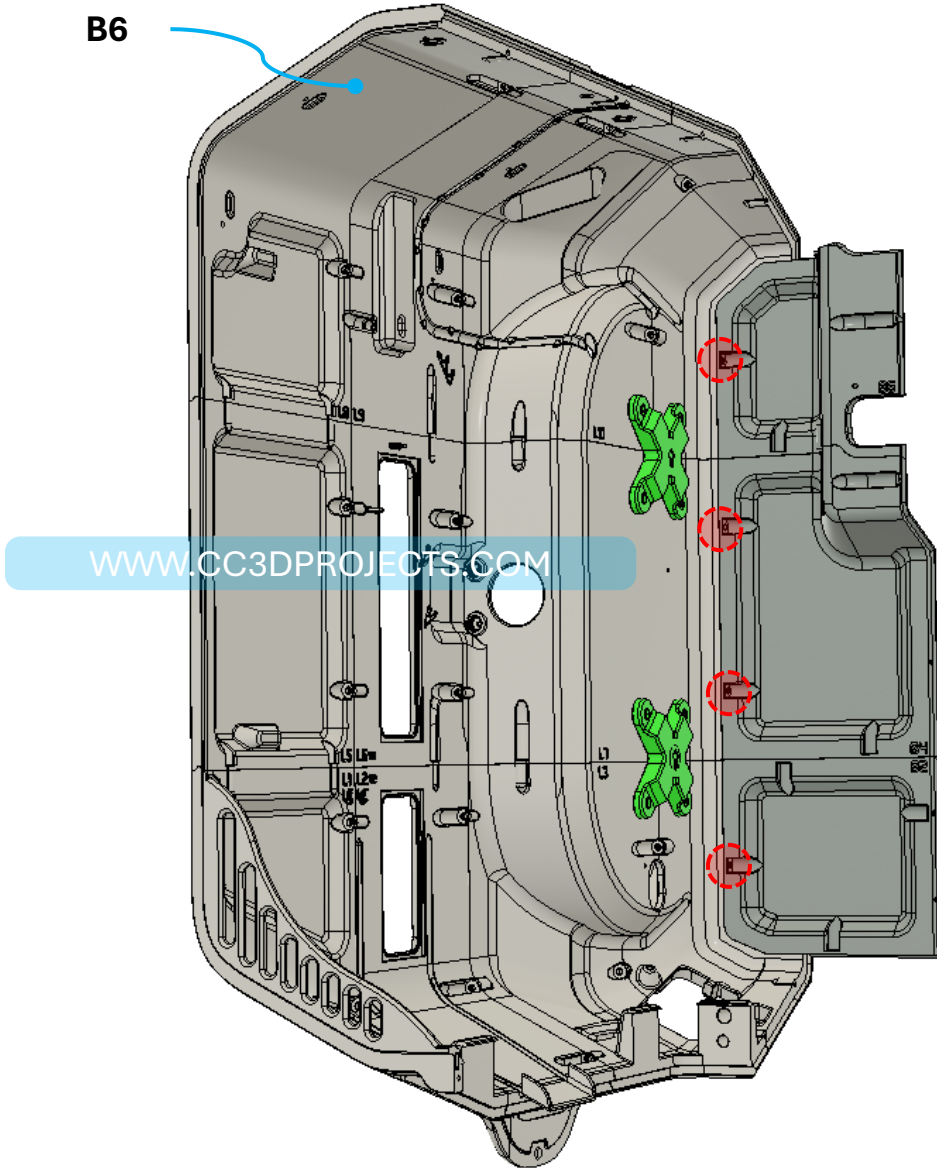
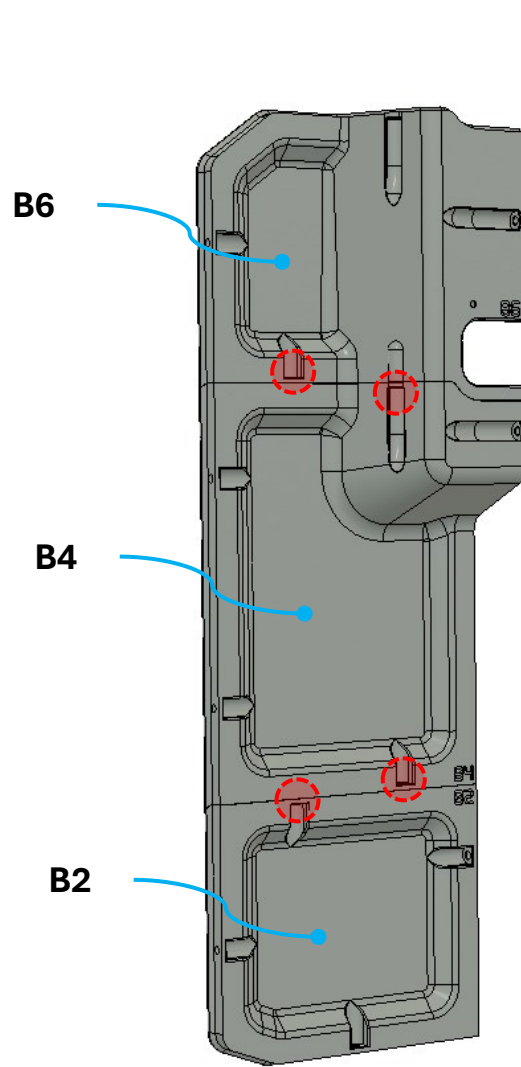

ALL MATERIAL PRODUCED AND PROVIDED HAS BEEN CONCEIVED, AUTHORED AND PRODUCED BY ENRICO MAZZAROL - ALL RIGHTS RESERVED.



# BACK PANEL ON LEFT PANEL

# ENCLOSURE A1



LET'S ADD HALF THE BACK PANELS!

NOW WE'RE GOING TO INSTALL HALF OF THE BACK PANELS ONTO THE LEFT SIDE OF THE ENCLOSURE. AS ALWAYS, JUST POP THE SCREWS INTO THE HOLES MARKED IN RED—AND THAT'S IT, YOU'RE GOOD TO GO!

LEFT  
SIDE

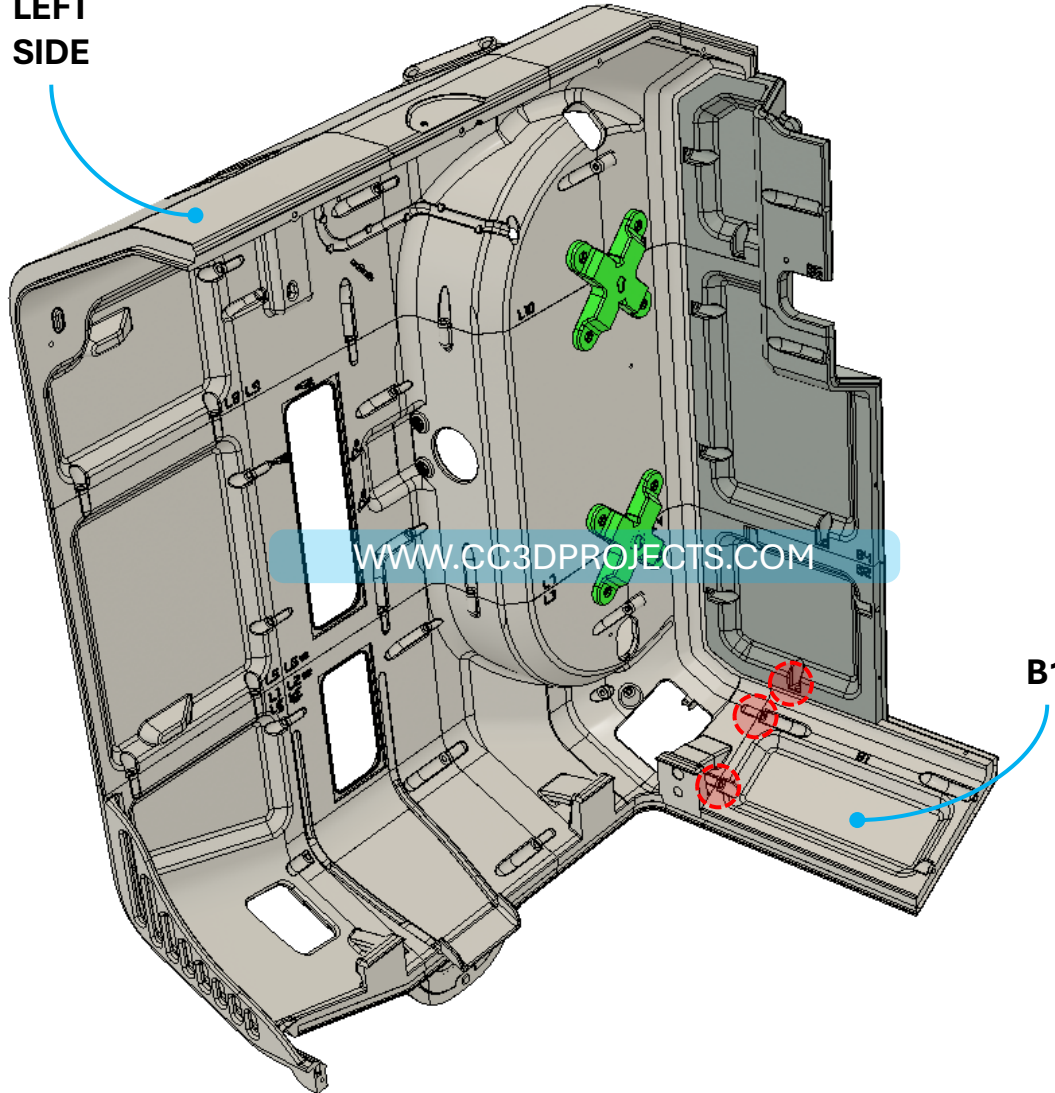

Buy me a coffee



ALL MATERIAL PRODUCED AND PROVIDED HAS BEEN CONCEIVED, AUTHORED AND PRODUCED BY ENRICO MAZZAROL - ALL RIGHTS RESERVED.



# TOP PANEL ON LEFT PANEL

# ENCLOSURE A1



## NOW LET'S ADD THE TOP PANEL!

JUST LIKE BEFORE, IT'S TIME TO INSTALL THE TOP PART OF THE ENCLOSURE ONTO THE LEFT SIDE OF THE STRUCTURE. LINE IT UP, INSERT THE SCREWS INTO THE RED-MARKED HOLES, TIGHTEN THEM UP—AND YOU'RE ALL SET!

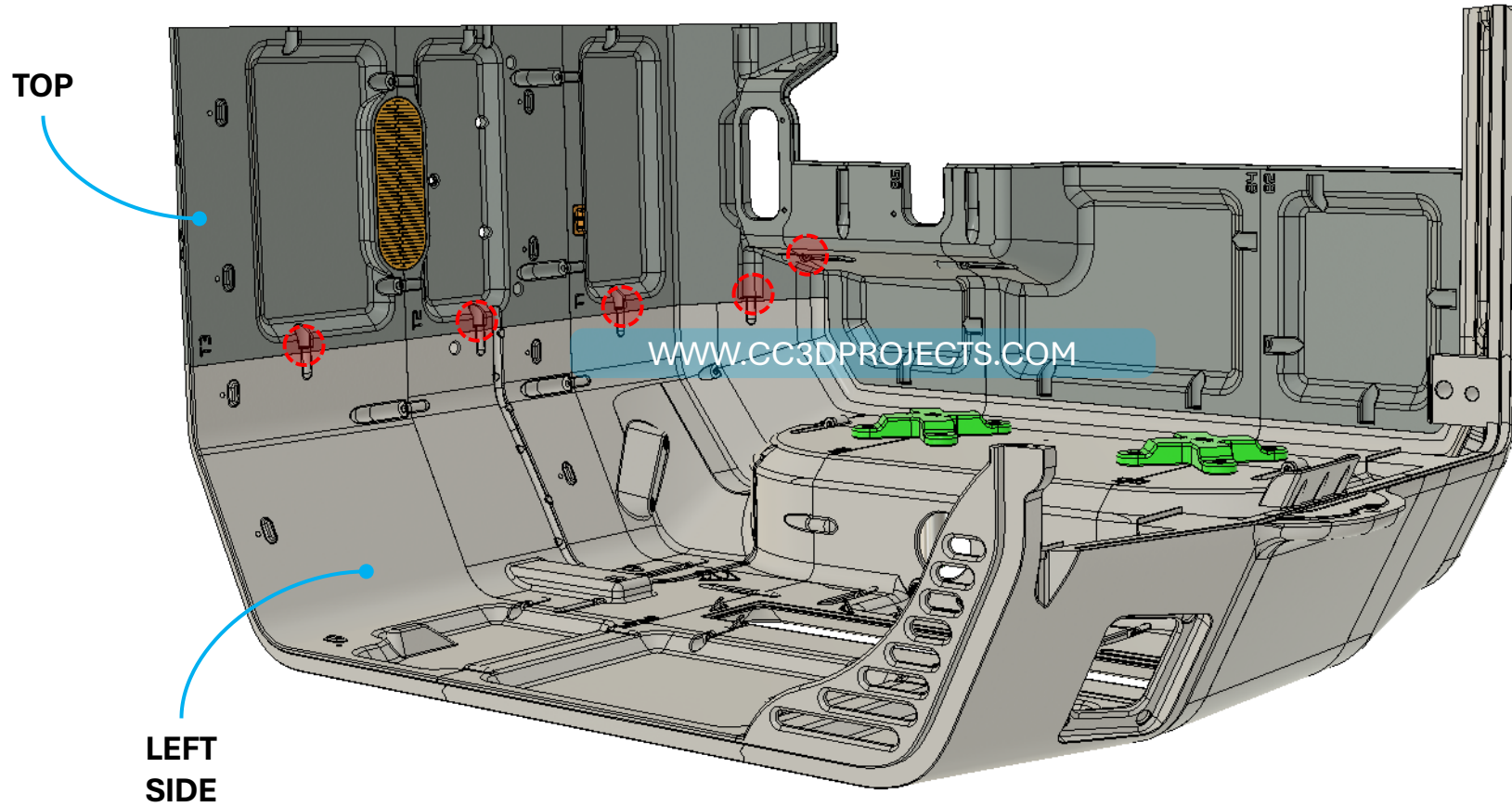

ALL MATERIAL PRODUCED AND PROVIDED HAS BEEN CONCEIVED, AUTHORED AND PRODUCED BY ENRICO MAZZAROL - ALL RIGHTS RESERVED.



# BACK PANEL ON RIGHT PANEL

NOW LET'S DO THE RIGHT SIDE! WE'RE REPEATING THE SAME STEPS WE DID ON THE LEFT SIDE—THIS TIME WITH THE RIGHT-SIDE PANELS. THERE'S JUST ONE SMALL DIFFERENCE: ON PANEL B5, YOU'LL ALSO NEED TO INSTALL A MAGNET. GRAB APPLICATOR A AND POP IT IN JUST LIKE YOU DID BEFORE. EASY!

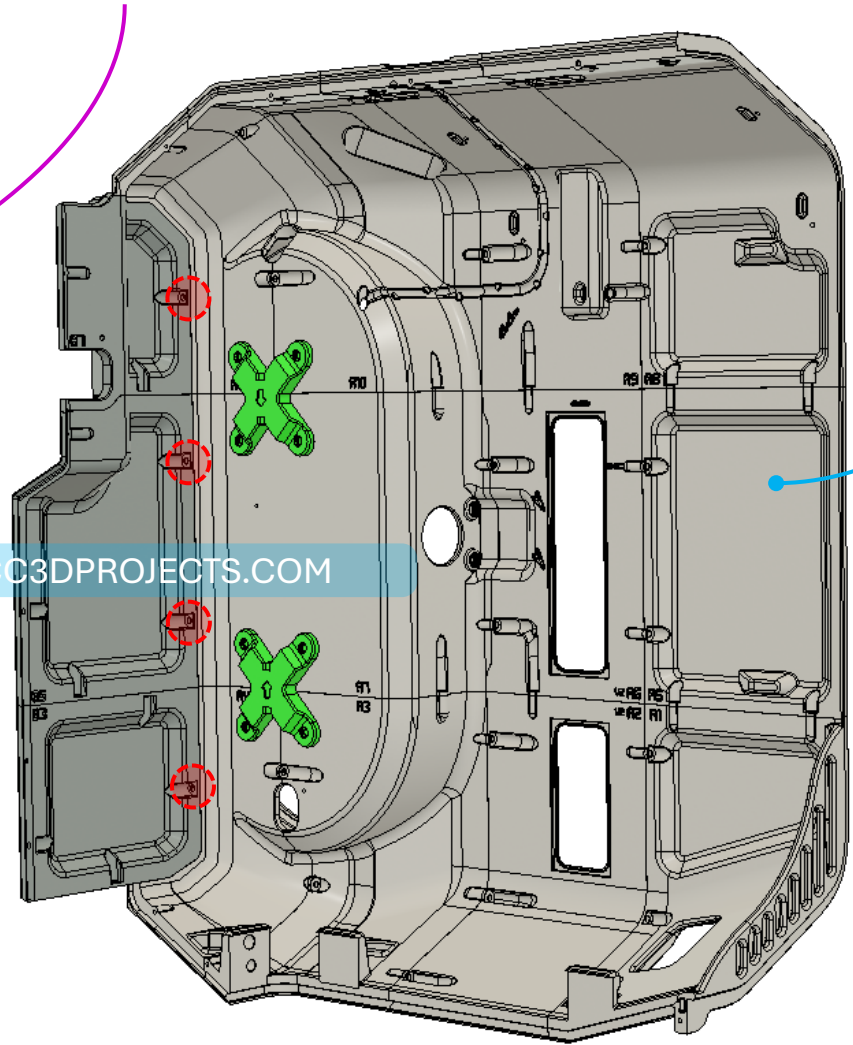
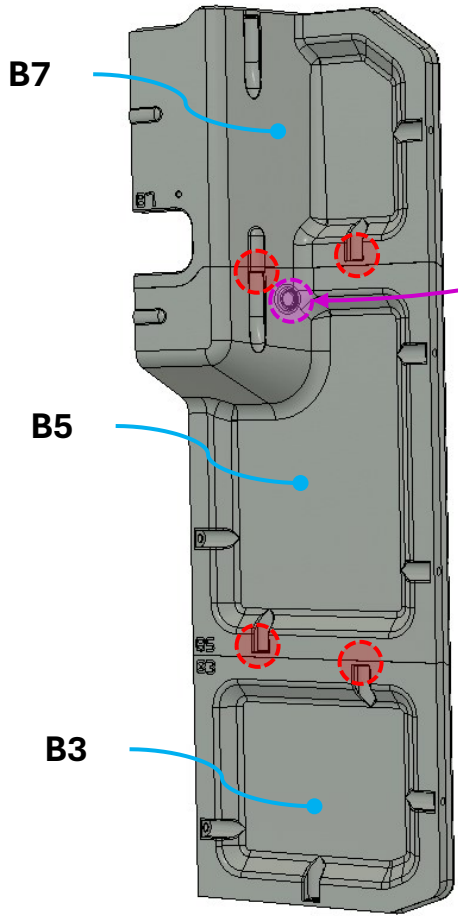

WWW.CC3DPROJECTS.COM

RIGHT SIDE

ALL MATERIAL PRODUCED AND PROVIDED HAS BEEN CONCEIVED, AUTHORED AND PRODUCED BY ENRICO MAZZAROL - ALL RIGHTS RESERVED.



# FULL FRAME ASSEMBLY

## TIME TO BRING IT ALL TOGETHER!

NOW LET'S JOIN THE LEFT SIDE WITH THE RIGHT SIDE.  
LINE EVERYTHING UP, INSERT THE SCREWS, AND TIGHTEN THEM DOWN TO LOCK IT ALL IN PLACE.  
LOOK AT THAT—IT'S REALLY STARTING TO COME TOGETHER!

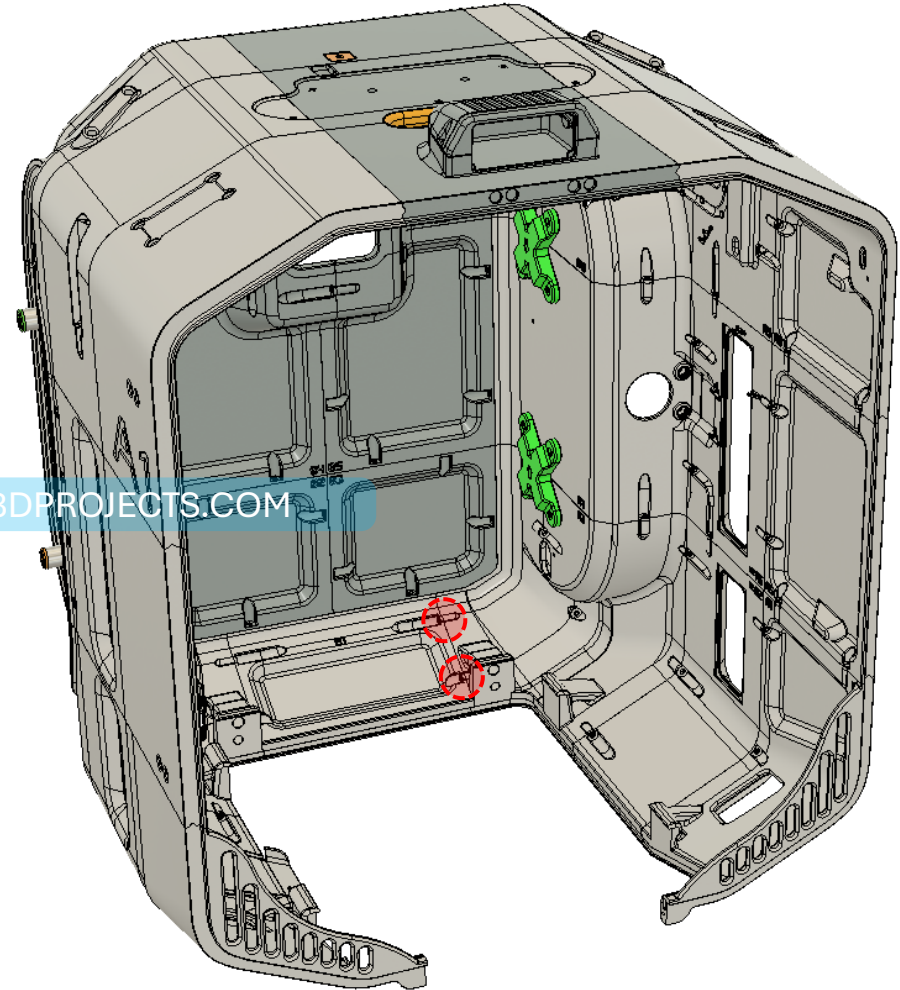
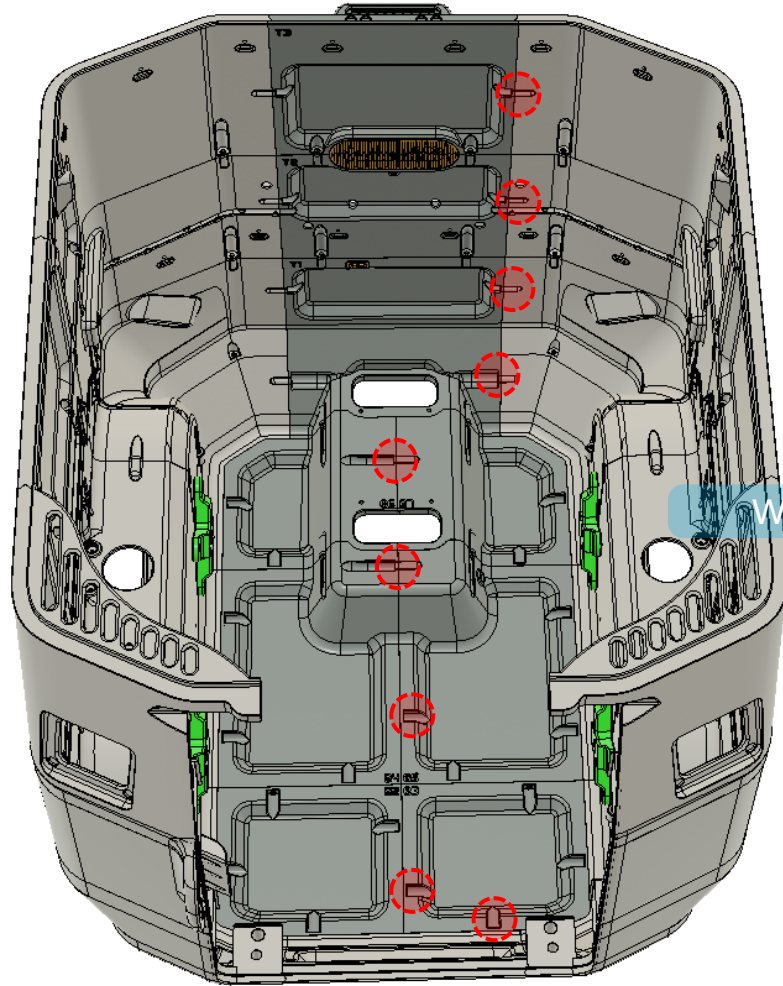

[WWW.CC3DPROJECTS.COM](http://WWW.CC3DPROJECTS.COM)

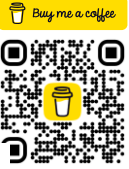



# FULL FRAME ASSEMBLY

# ENCLOSURE A1



## LET'S FINISH THE MAIN STRUCTURE!

WE'RE ALMOST THERE—JUST ONE LAST PIECE TO ADD!

BEFORE YOU SCREW IT IN (YOU'LL ONLY NEED TWO SCREWS), DON'T FORGET TO INSTALL THE MAGNETS INTO THE PINK-MARKED HOLES USING APPLICATOR **A**.

ONCE THE MAGNETS ARE IN PLACE, GO AHEAD AND SECURE THE PIECE WITH THOSE TWO SCREWS.

BOOM! MAIN STRUCTURE: COMPLETE.

Buy me a coffee



F1

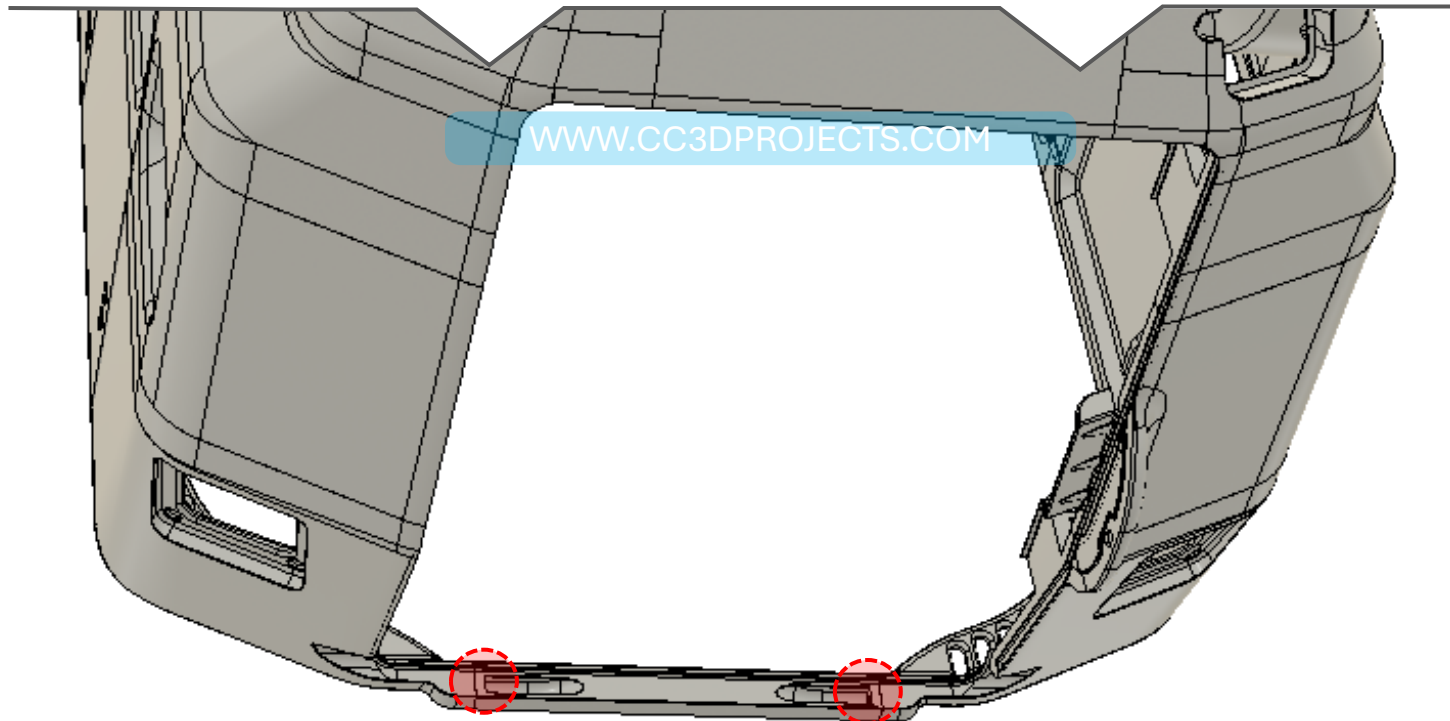
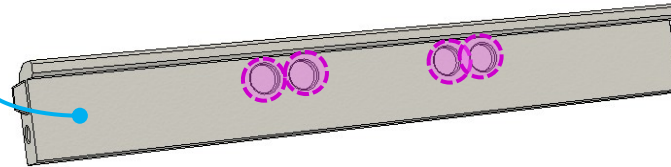

WWW.CC3DPROJECTS.COM



# HINGE FRAME INSTALLATION

## LET'S INSTALL THE HINGE SOCKETS!

TIME TO MOUNT THE HINGE SOCKETS ONTO THE STRUCTURE—BOTH FOR THE FRONT DOORS AND THE FILAMENT ACCESS DOORS. KEEP AN EYE ON THE CODES PRINTED ON THE HINGES—THEY'LL HELP GUIDE YOU THROUGH THE CORRECT PLACEMENT. JUST MATCH 'EM UP AND YOU'RE GOOD TO GO!

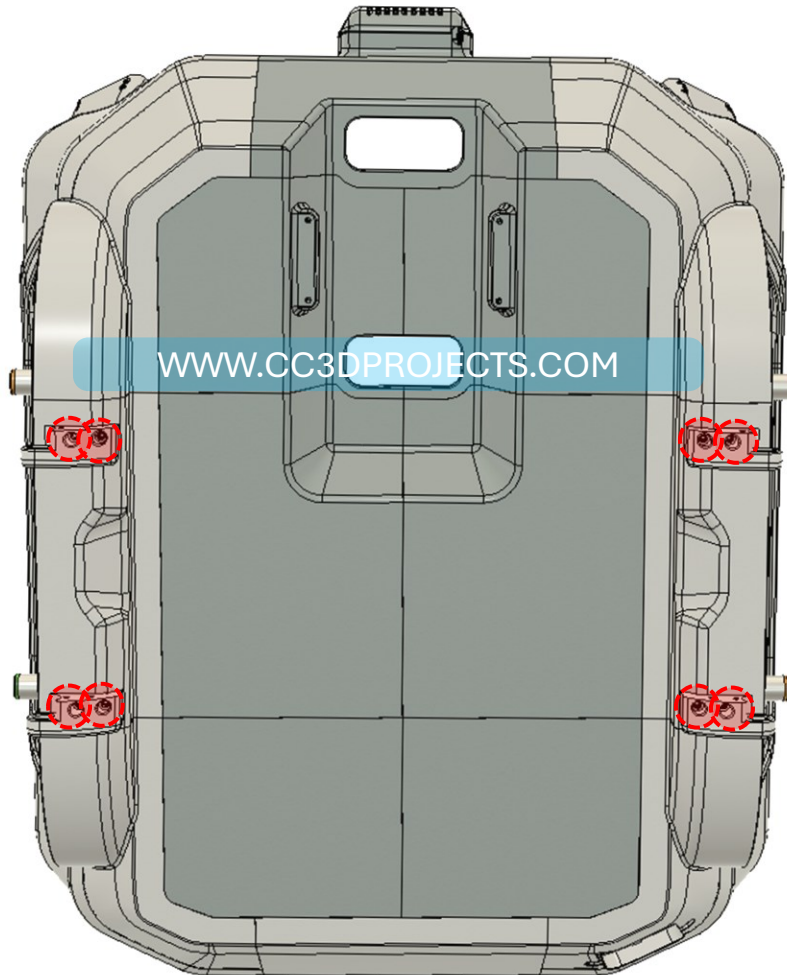
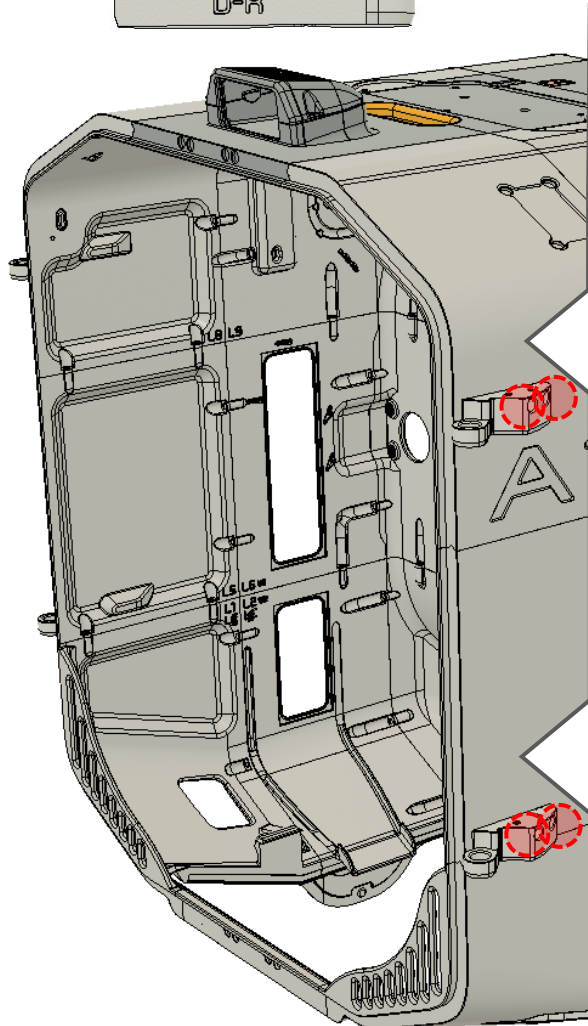
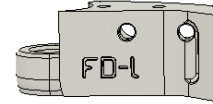
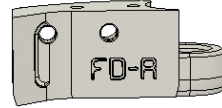

[WWW.CC3DPROJECTS.COM](http://WWW.CC3DPROJECTS.COM)

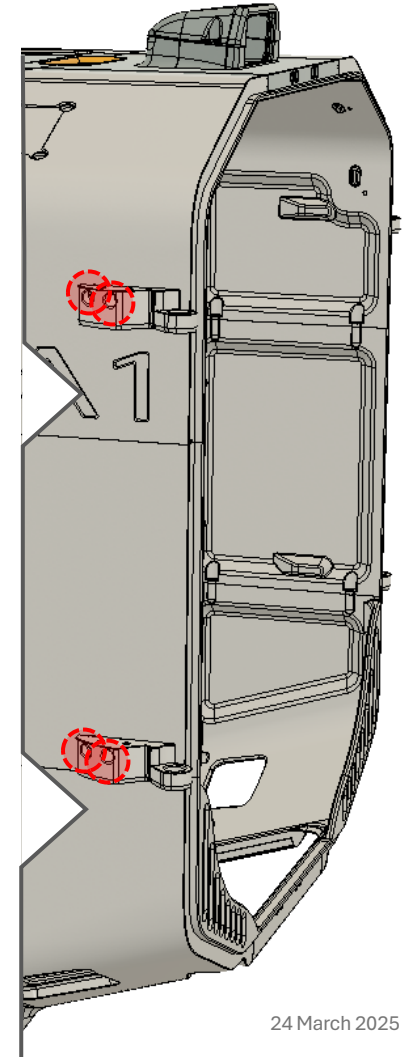



# FILAMENT DOORS

## LET'S BUILD THE FILAMENT COMPARTMENT DOOR!

NOW WE'RE ASSEMBLING THE FILAMENT DOOR ON THE RIGHT SIDE OF THE STRUCTURE. START BY JOINING THE PARTS TOGETHER USING THE 3 SCREWS—NICE AND SNUG.

ONCE THAT'S DONE, GLUE IN THE MAGNETS USING APPLICATOR **B**. YEP, IT'S THAT EASY!

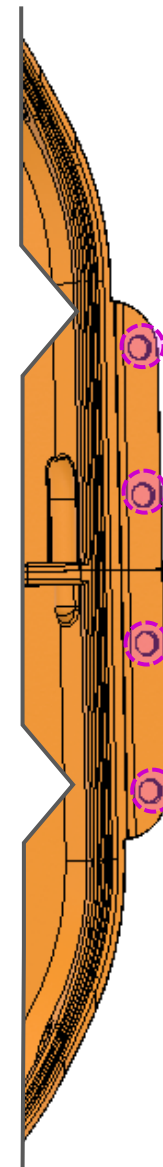
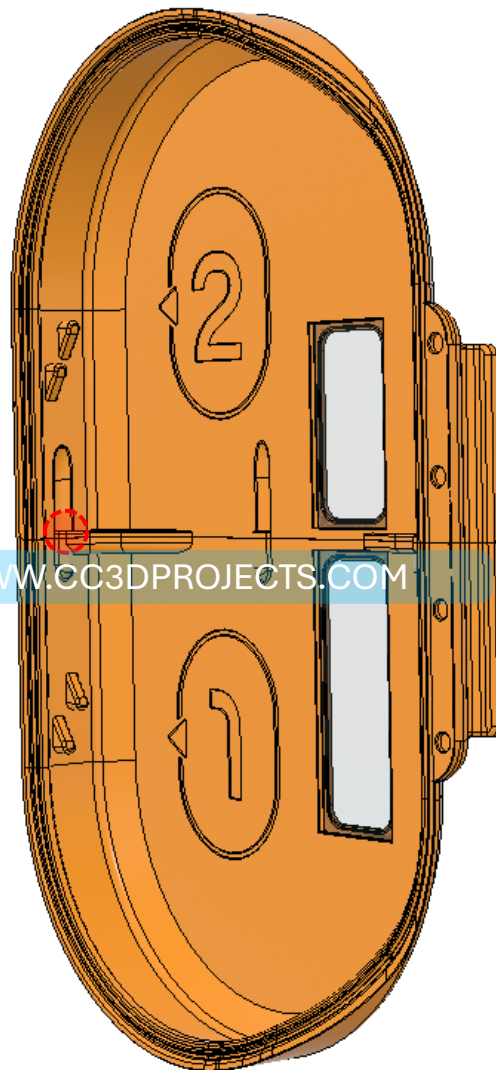
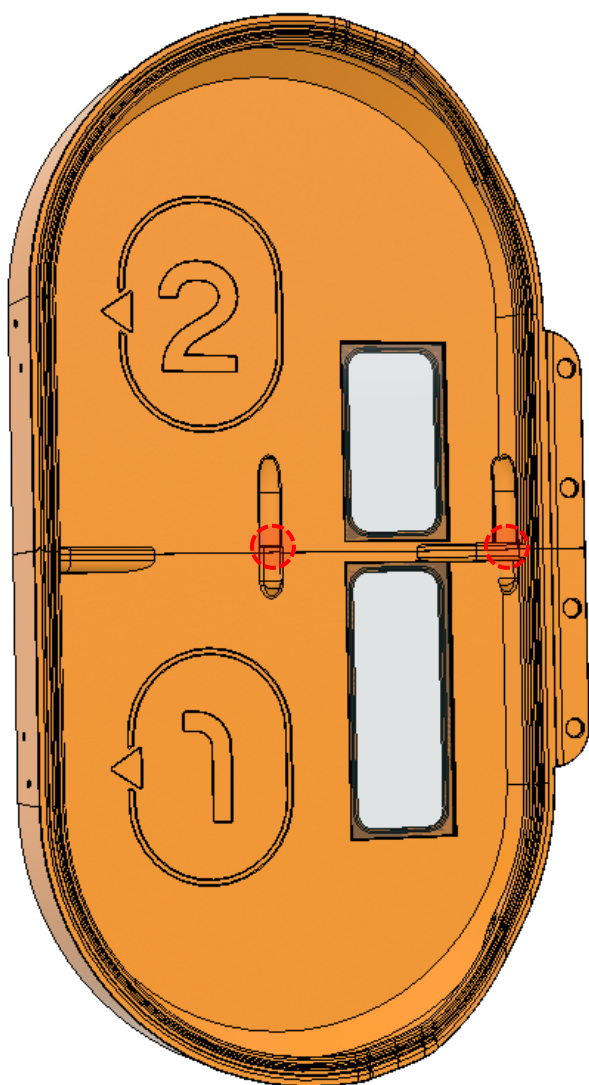

Buy me a coffee





# FILAMENT DOORS

# ENCLOSURE A1



**NOW LET'S BUILD THE FILAMENT COMPARTMENT DOOR ON THE LEFT SIDE!**

SAME DEAL AS BEFORE—ASSEMBLE THE DOOR ON THE LEFT SIDE BY JOINING THE PARTS WITH 3 SCREWS.

THEN, GRAB APPLICATOR **B** AND GLUE IN THE MAGNETS JUST LIKE YOU DID ON THE OTHER SIDE.

NICE WORK—SYMMETRY IS BEAUTIFUL!

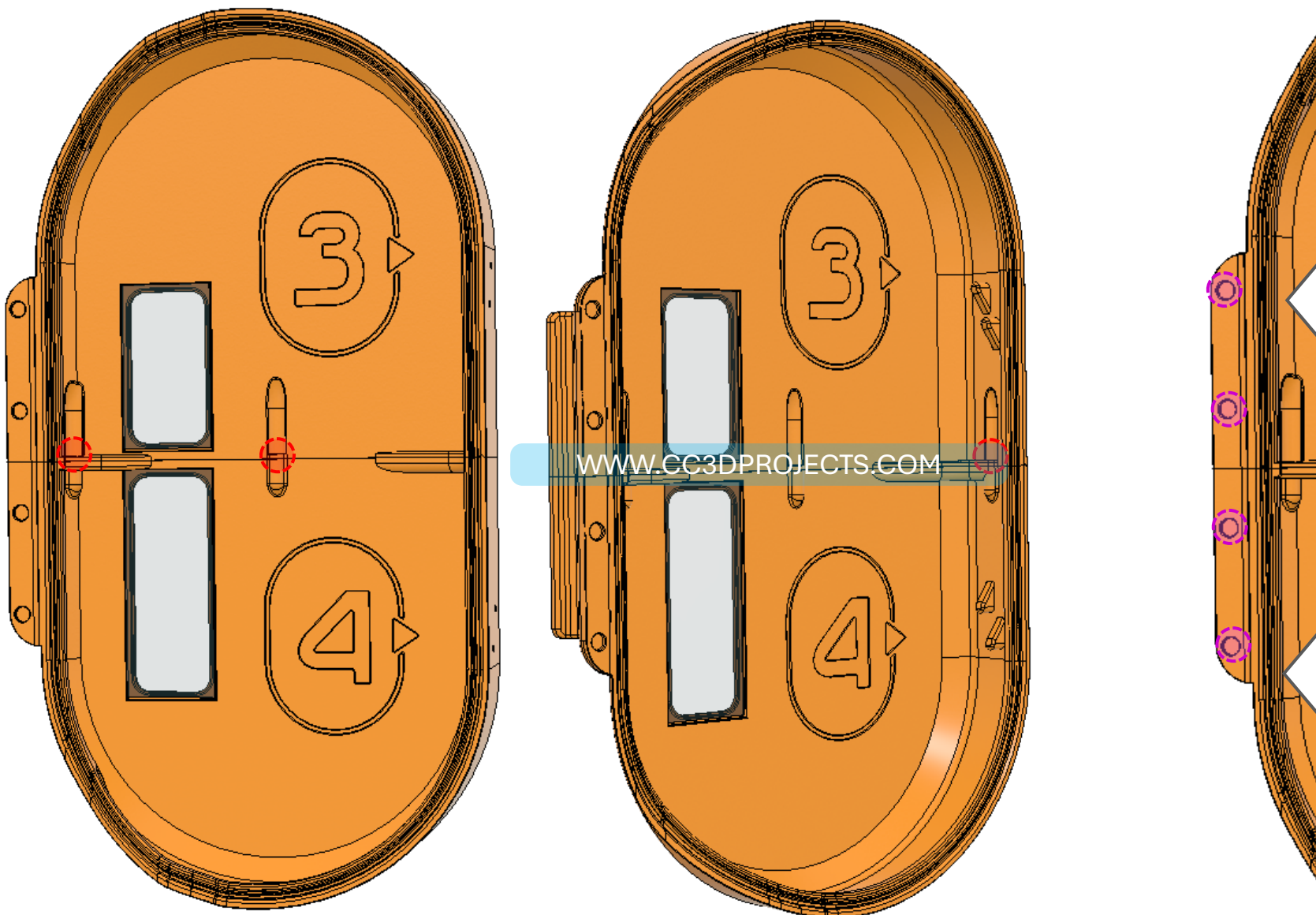

Buy me a coffee





# FILAMENT DOORS

# ENCLOSURE A1



## TIME TO ADD THE HINGES FOR THE FILAMENT DOORS!

NOW LET'S INSTALL THE HINGE PARTS ONTO THE FILAMENT DOORS.

MAKE SURE TO FOLLOW THE HINGE CODES EXACTLY AS SHOWN IN THE IMAGES—THEY'RE THERE TO MAKE YOUR LIFE EASIER!

USE THE SCREWS IN THE HIGHLIGHTED HOLES TO LOCK EVERYTHING IN PLACE.

LOOKING GOOD—THOSE DOORS ARE ALMOST READY TO SWING!

Buy me a coffee

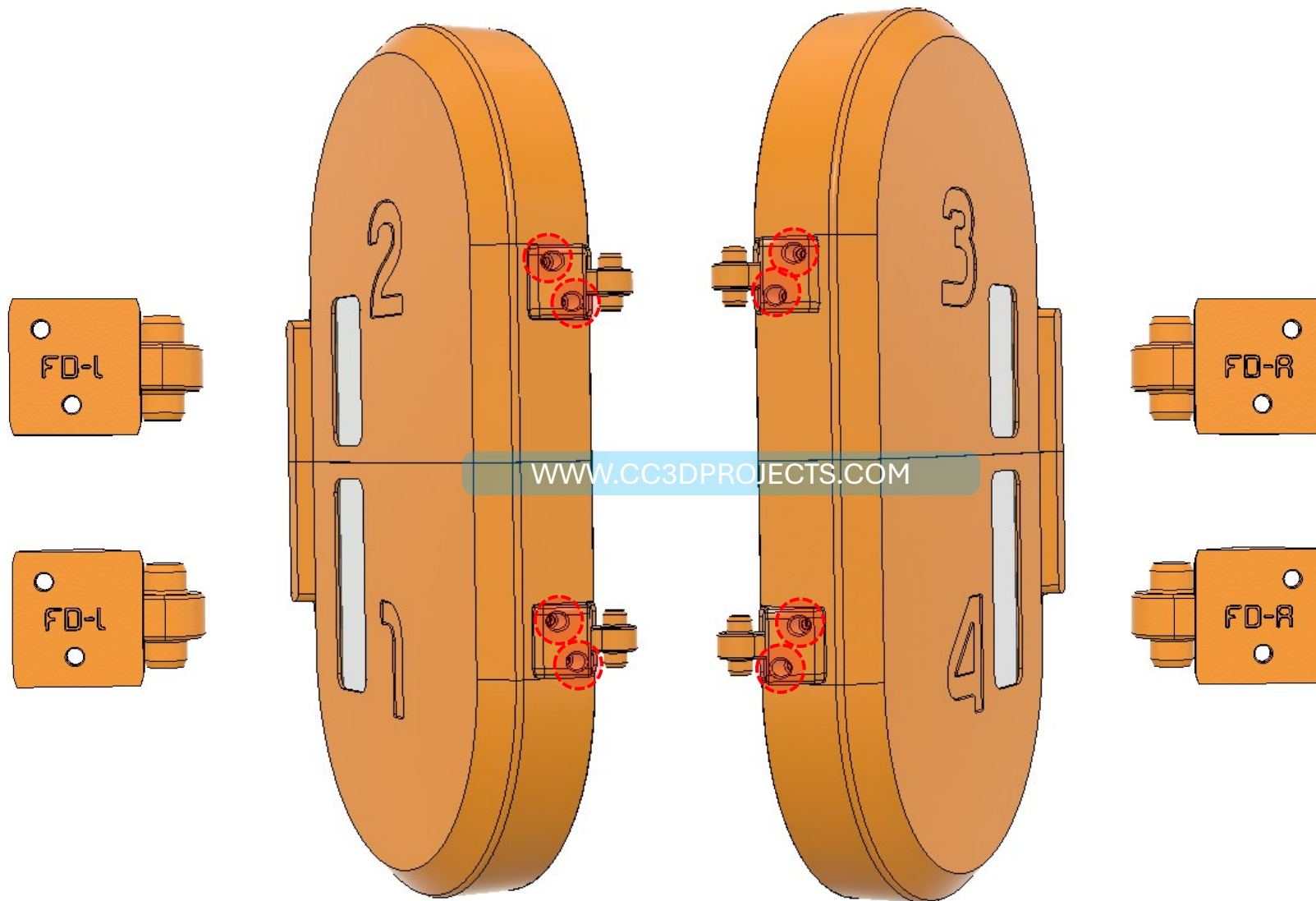



# ENCLOSURE DOORS

# ENCLOSURE A1



LET'S START ASSEMBLING THE FRONT DOORS! SCREWS? EASY—YOU'VE GOT THIS. BUT WHEN IT COMES TO THE MAGNETS, PAY CLOSE ATTENTION! ON THE RIGHT FRAME, USE APPLICATOR **B**. ON THE LEFT FRAME, USE APPLICATOR **A**.

YEP, THEY'RE DIFFERENT—SO DOUBLE-CHECK BEFORE GLUING! ONCE THAT'S DONE, YOU'RE ONE BIG STEP CLOSER TO THE FINISH LINE!

Buy me a coffee

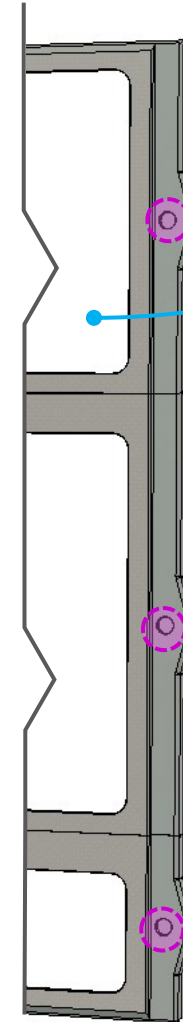
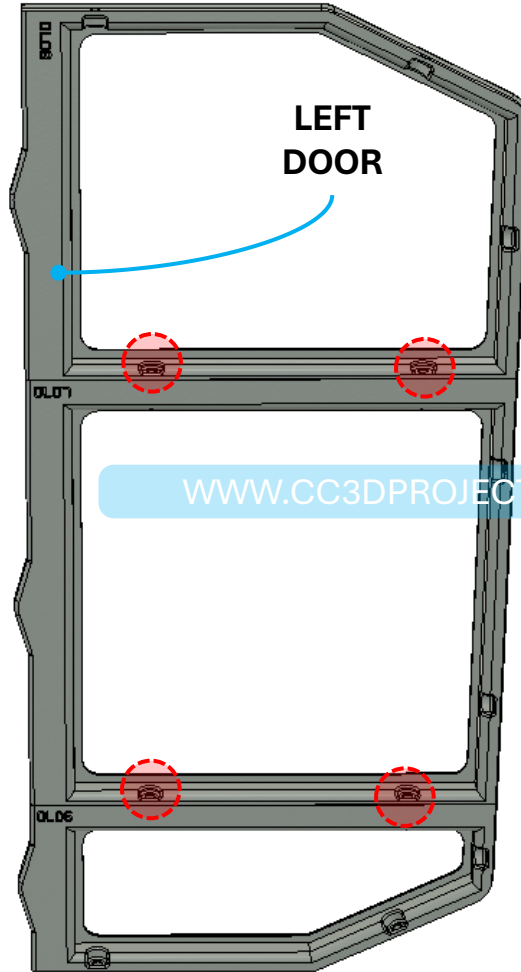
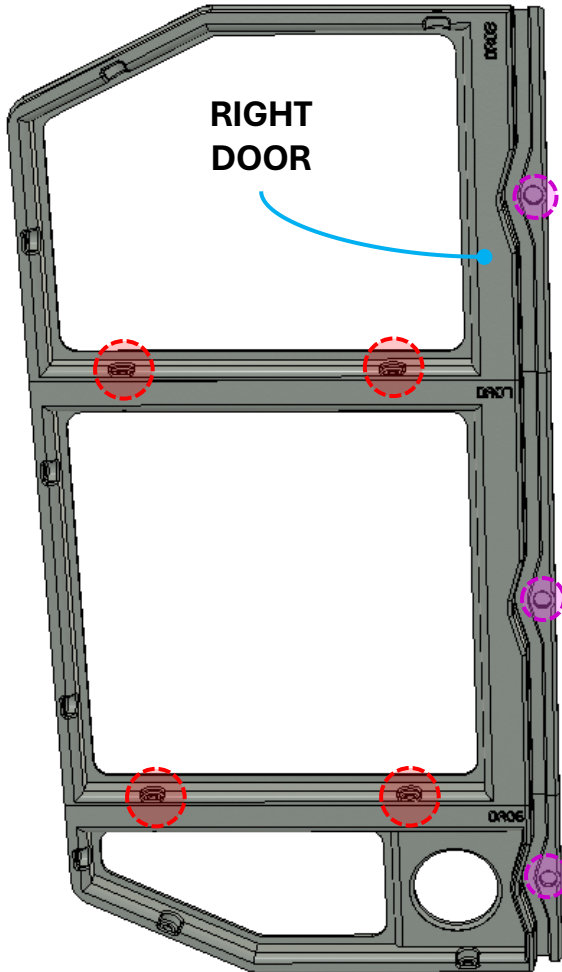

WWW.CC3DPROJECTS.COM

ALL MATERIAL PRODUCED AND PROVIDED HAS BEEN CONCEIVED, AUTHORED AND PRODUCED BY ENRICO MAZZAROL - ALL RIGHTS RESERVED.



# ENCLOSURE DOOR GLASSES

# ENCLOSURE A1



Buy me a coffee

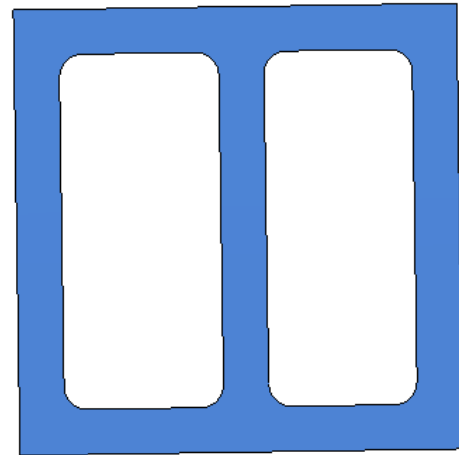
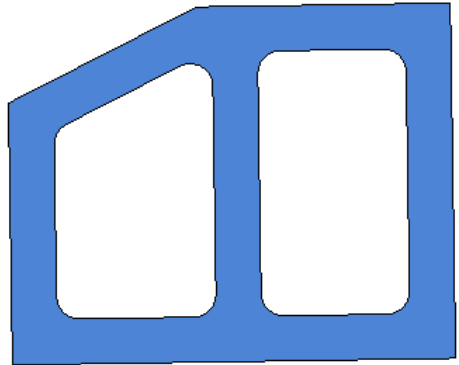

### LET'S CUT AND GLUE THE FRONT DOOR WINDOWS!

NOW IT'S TIME TO CUT AND GLUE THE WINDOWS ONTO THE FRONT DOORS. IF I'M NOT MISTAKEN, YOU SHOULD HAVE ALREADY PRINTED THOSE ODDLY-SHAPED MOCKUPS—YEP, THE ONES THAT MATCH THE SHAPES SHOWN IN THE IMAGE. USE THEM AS TEMPLATES TO CUT OUT THE GLASS PIECES. YOU'LL NEED **TWO PIECES FOR EACH SHAPE**. ONCE THEY'RE READY, GLUE THEM IN PLACE—AND WHEN YOU'RE DONE, HEAD ON OVER TO THE NEXT PAGE!

[WWW.CC3DPROJECTS.COM](http://WWW.CC3DPROJECTS.COM)



# ENCLOSURE DOOR GLASSES

# ENCLOSURE A1



**THIS PART'S ALL ABOUT PRECISION AND CLEAN WORK!**

APPLY A THIN, EVEN LAYER OF GLUE INTO THE GROOVES OF THE FRAMES—NEATNESS MATTERS HERE!  
THEN, GENTLY PLACE THE GLASS PIECES ON TOP. NO NEED TO PRESS TOO HARD—JUST LET THEM SETTLE IN.  
WHILE THE GLUE DRIES, GO AHEAD AND MOVE ON TO THE NEXT PAGE. LET THOSE WINDOWS SET IN PEACE!

Buy me a coffee

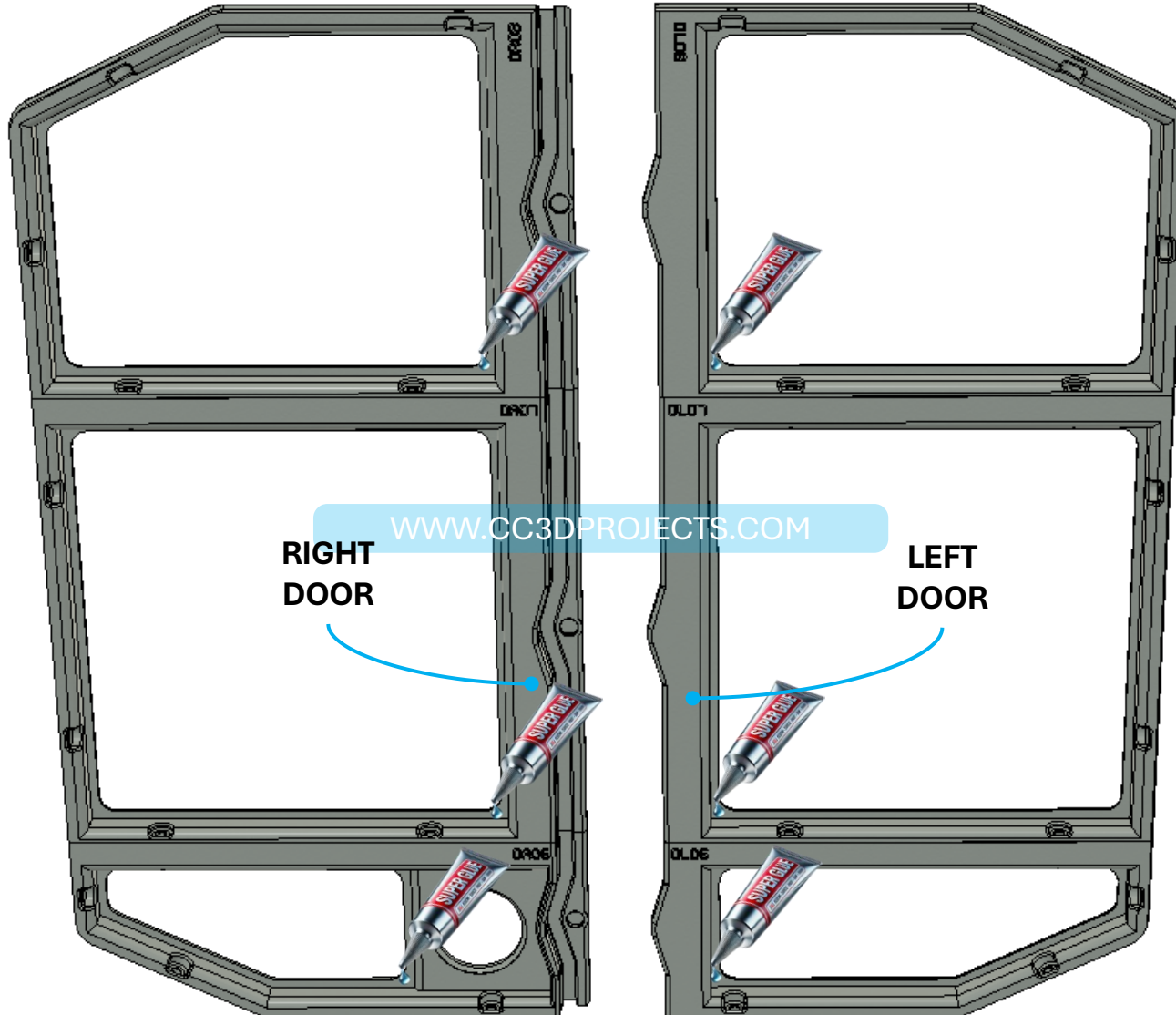

ALL MATERIAL PRODUCED AND PROVIDED HAS BEEN CONCEIVED, AUTHORED AND PRODUCED BY ENRICO MAZZAROL - ALL RIGHTS RESERVED.



# ENCLOSURE LEFT DOOR

# ENCLOSURE A1



## LET'S WORK ON THE LEFT FRONT DOOR FRAME!

THIS ONE'S A MIXED SETUP—SO HERE'S HOW IT GOES:

START BY GLUING THE **MAIN PIECES** TOGETHER ON A FLAT SURFACE. KEEP IT NICE AND LEVEL FOR A CLEAN, SOLID BOND.

ONCE THAT'S DRY ENOUGH TO HANDLE, MOVE ON TO **SCREWING IN THE OUTER PIECES**—THEY'LL LOCK EVERYTHING IN PLACE.

LAST STEP: GLUE THE MAGNETS INTO THE HIGHLIGHTED HOLES USING **APPLICATOR B**.

BOOM—LEFT FRAME DONE LIKE A PRO!

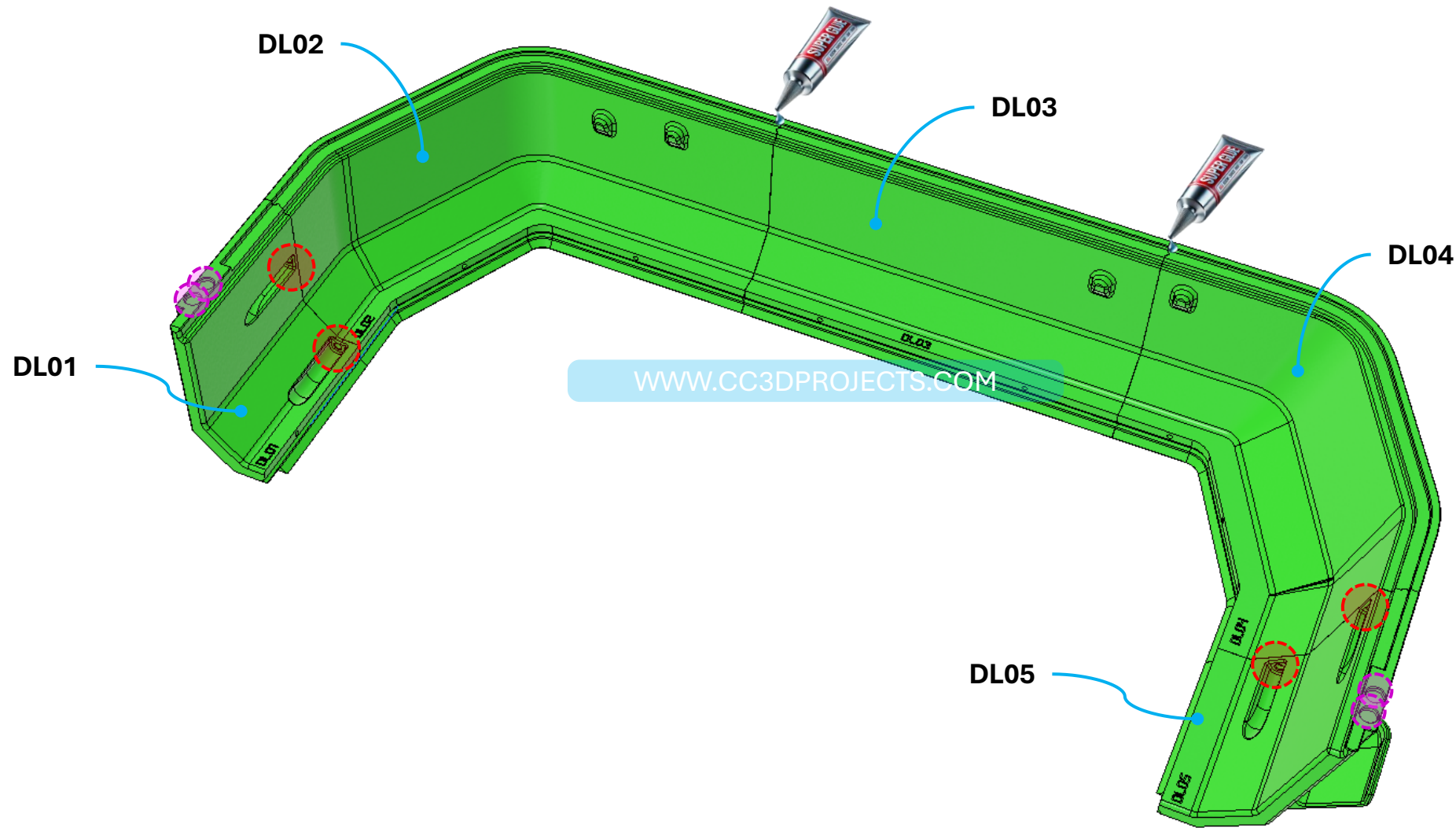

WWW.CC3DPROJECTS.COM

ALL MATERIAL PRODUCED AND PROVIDED HAS BEEN CONCEIVED, AUTHORED AND PRODUCED BY ENRICO MAZZAROL - ALL RIGHTS RESERVED.



# ENCLOSURE RIGHT DOOR

# ENCLOSURE A1



## NOW LET'S BUILD THE RIGHT FRONT DOOR FRAME!

SAME MIXED SETUP AS BEFORE—GLUE AND SCREWS WORKING TOGETHER. START BY GLUING THE **MAIN PIECES** ON A FLAT SURFACE, MAKING SURE EVERYTHING IS LINED UP NICE AND STRAIGHT. ONCE THAT'S DONE, **SCREW IN THE OUTER PIECES** TO LOCK THE FRAME IN PLACE. FINALLY, GLUE THE MAGNETS INTO THE HIGHLIGHTED HOLES USING **APPLICATOR B**. AND THAT'S IT—THE RIGHT FRAME IS READY TO ROLL!

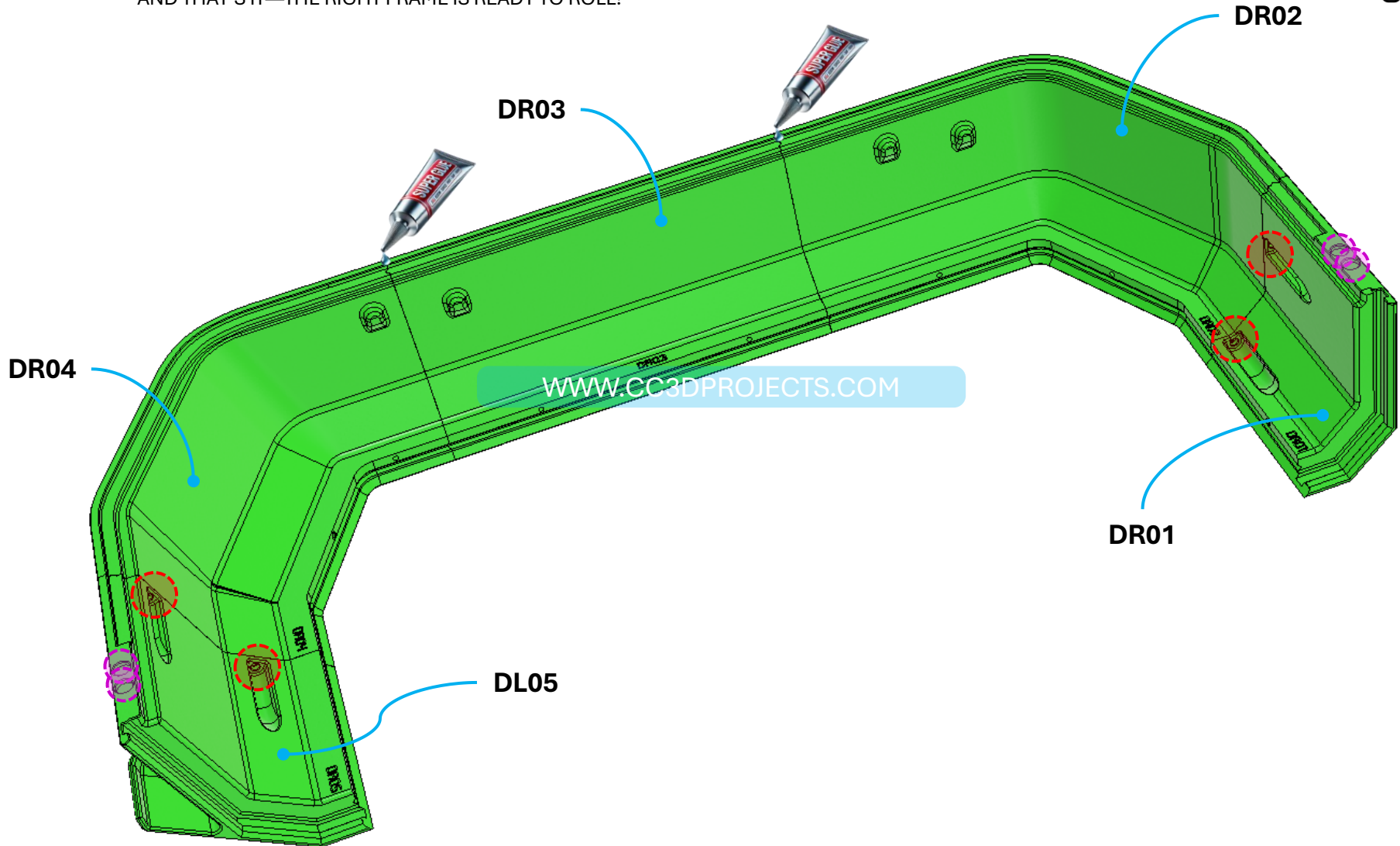

ALL MATERIAL PRODUCED AND PROVIDED HAS BEEN CONCEIVED, AUTHORED AND PRODUCED BY ENRICO MAZZAROL - ALL RIGHTS RESERVED.



# ENCLOSURE LEFT DOOR

# ENCLOSURE A1



LET'S ASSEMBLE THE LEFT DOOR! TIME TO BRING IT ALL TOGETHER—COMBINE THE CENTER FRAME (WITH THE GLASS) AND THE OUTER FRAME FOR THE LEFT DOOR. FIRST, MAKE SURE THE CODES ON BOTH PARTS START WITH **DL**—THAT'S HOW YOU KNOW YOU'VE GOT THE RIGHT MATCH. ONCE CONFIRMED, LINE UP THE PIECES CAREFULLY AND FASTEN THEM TOGETHER USING ONE SCREW PER HIGHLIGHTED HOLE. CLICK, CLICK, DONE—LEFT DOOR COMING TO LIFE!

Buy me a coffee

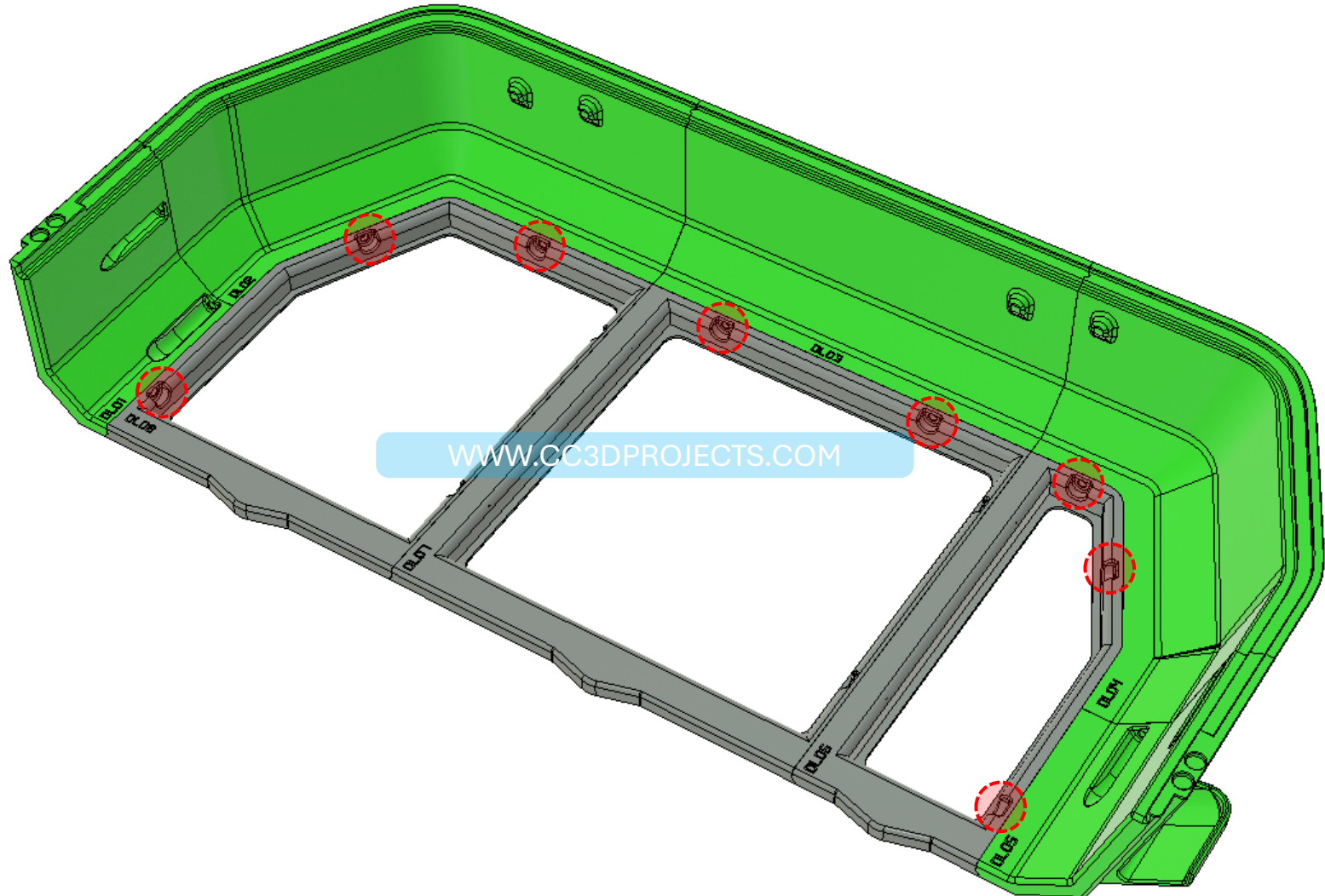



# ENCLOSURE RIGHT DOOR

# ENCLOSURE A1



LET'S ASSEMBLE THE RIGHT DOOR! NOW IT'S TIME TO PUT TOGETHER THE CENTER FRAME (WITH THE GLASS) AND THE OUTER FRAME FOR THE RIGHT DOOR. DOUBLE-CHECK THAT THE CODES ON BOTH PARTS START WITH **DR**—THAT MEANS THEY'RE THE CORRECT PAIR. ONCE YOU'VE GOT THE RIGHT MATCH, ALIGN THE PIECES AND SECURE THEM WITH ONE SCREW IN EACH HIGHLIGHTED HOLE. NICE AND EASY—THE RIGHT DOOR IS READY TO SHINE!

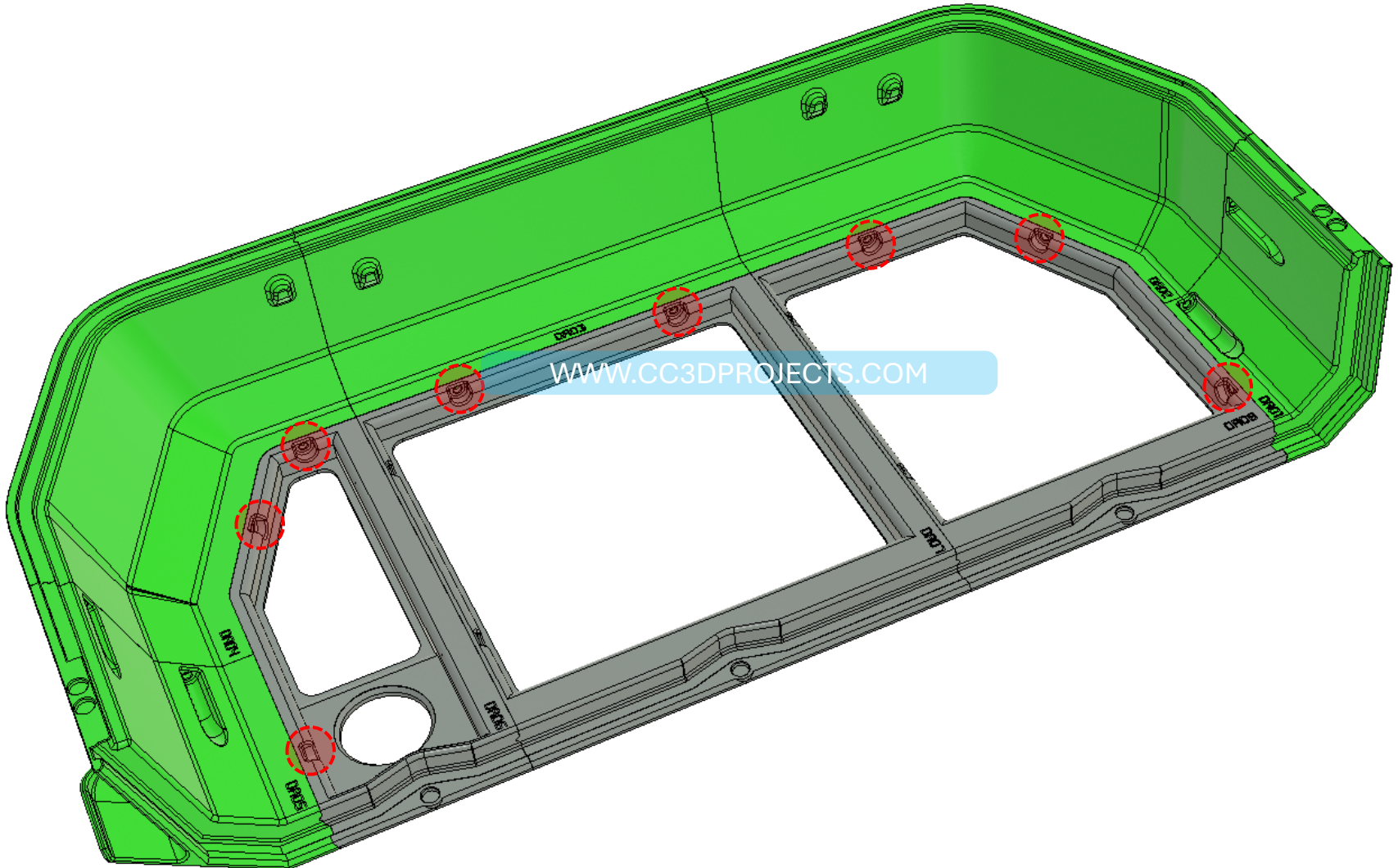

ALL MATERIAL PRODUCED AND PROVIDED HAS BEEN CONCEIVED, AUTHORED AND PRODUCED BY ENRICO MAZZAROL - ALL RIGHTS RESERVED.



# ENCLOSURE DOOR HINGES

**QUICK AND EASY—LET’S INSTALL THE FRONT DOOR HINGES!**  
THIS ONE’S A BREEZE!  
JUST MATCH THE HINGE PARTS TO THE CORRECT DOORS—**FOLLOW THE CODES**, AND YOU WON’T RUN INTO ANY TROUBLE.  
LINE THEM UP, SCREW THEM IN, AND YOU’RE ALL SET.  
ON TO THE NEXT STEP LIKE A PRO!

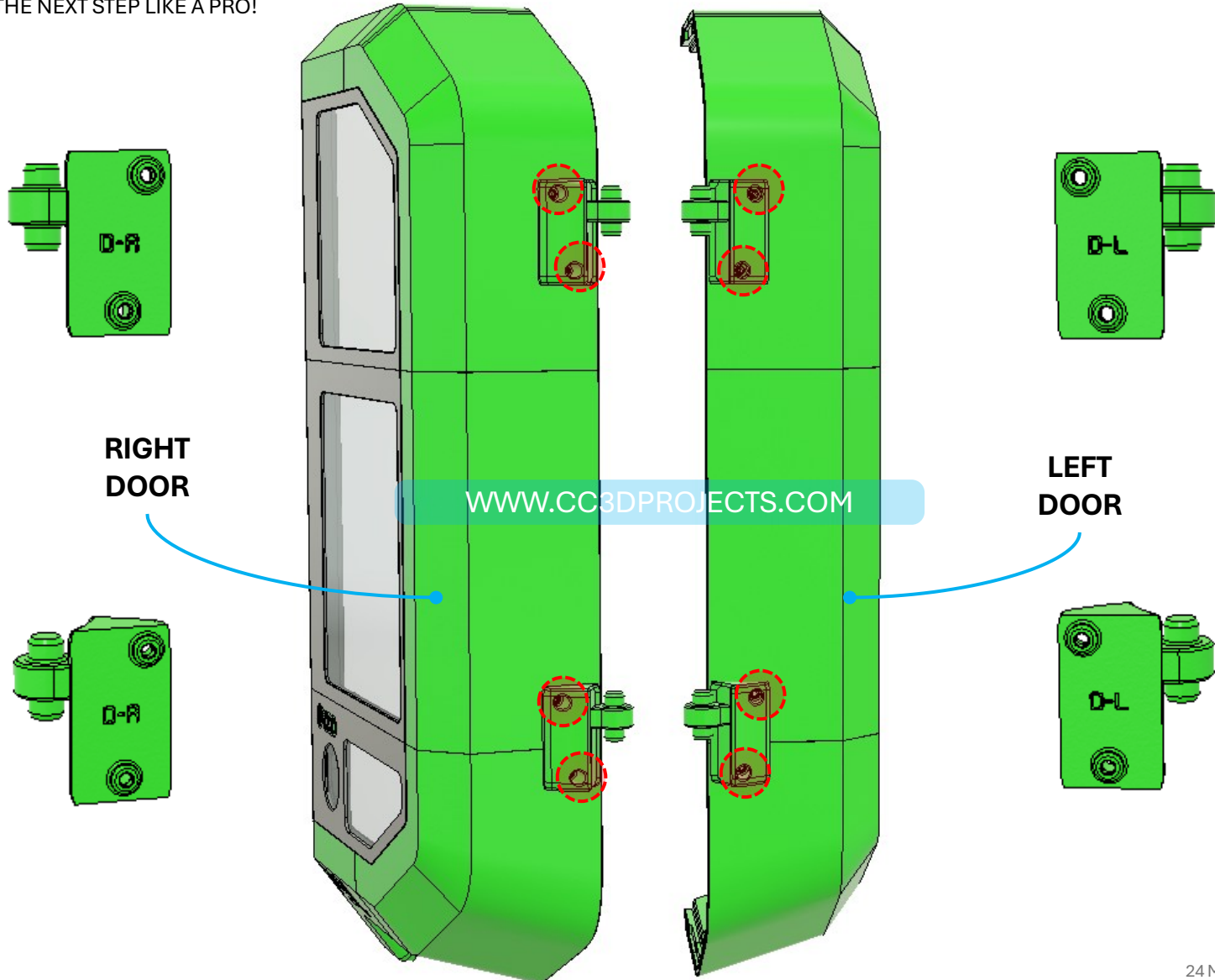

ALL MATERIAL PRODUCED AND PROVIDED HAS BEEN CONCEIVED, AUTHORED AND PRODUCED BY ENRICO MAZZAROL - ALL RIGHTS RESERVED.



# ENCLOSURE DOOR GASKET

## TIME TO INSTALL THE SEALS ON THE FRONT DOORS!

YOU'LL NOTICE THERE ARE GROOVES THAT ARE 6 MM WIDE—THOSE ARE MADE JUST FOR THE 6X3 MM GASKET. SIMPLY PRESS THE GASKET INTO THE GROOVE ALONG THE INSIDE EDGE OF EACH DOOR. TAKE YOUR TIME AND MAKE SURE IT SITS NICE AND FLUSH ALL THE WAY AROUND. THAT SEAL'S GONNA KEEP THINGS CLEAN AND TIGHT—NICE WORK!

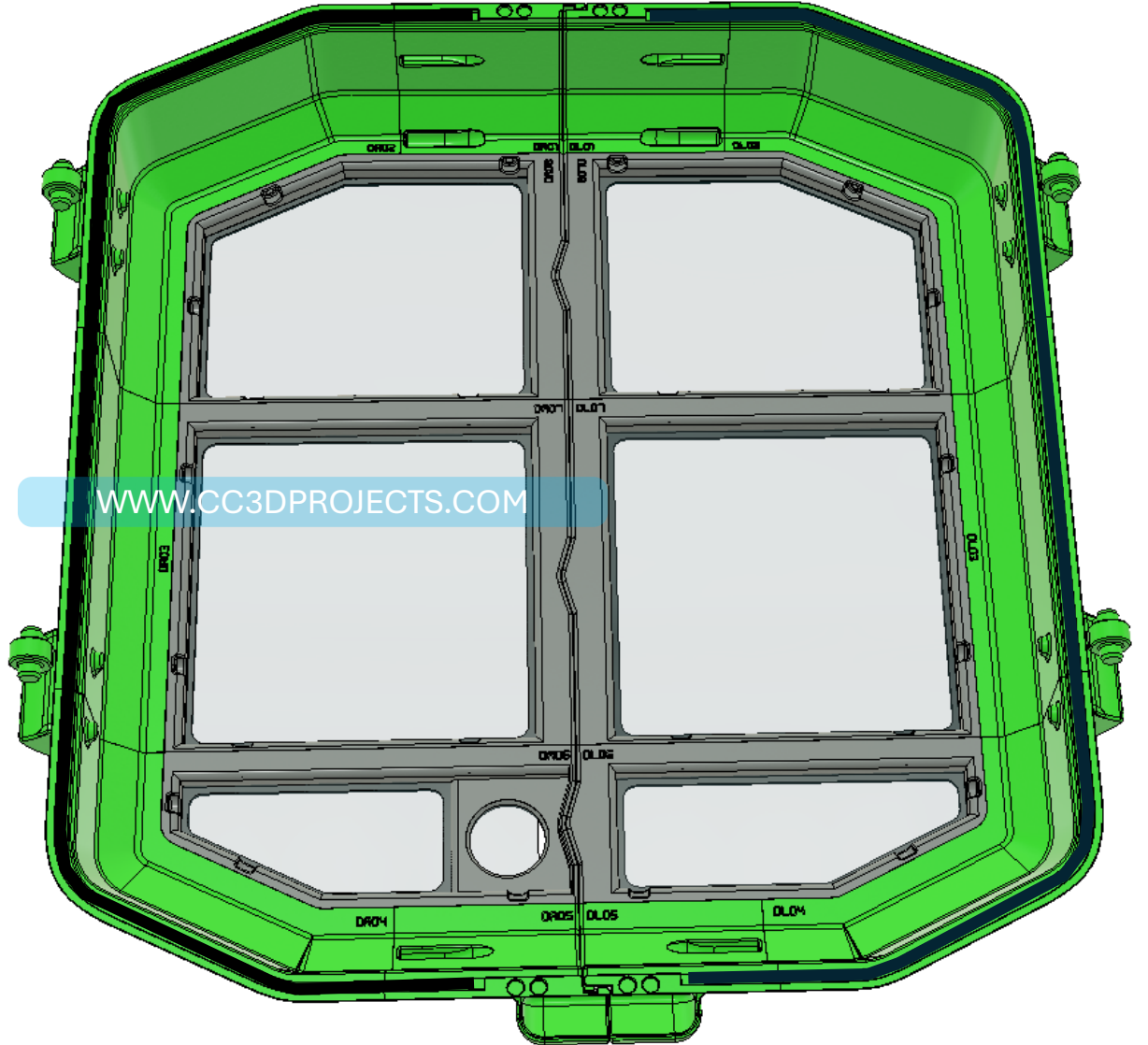
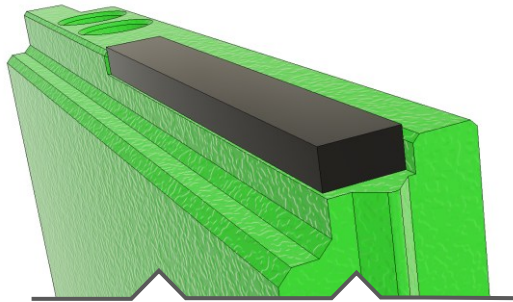



# ENCLOSURE LOWER GASKET

# ENCLOSURE A1



**NOW LET'S INSTALL THE SEAL ON THE BOTTOM OF THE ENCLOSURE!**

YOU'LL SEE A GROOVE DOWN THERE THAT'S 6 MM WIDE—THAT'S WHERE THE **6X3 MM GASKET** GOES. PRESS THE GASKET FIRMLY INTO THE GROOVE, MAKING SURE IT FITS SNUGLY ALL THE WAY ACROSS. TAKE IT SLOW AND KEEP IT CLEAN—THIS SEAL HELPS KEEP THINGS TIDY AND AIRTIGHT DOWN BELOW!

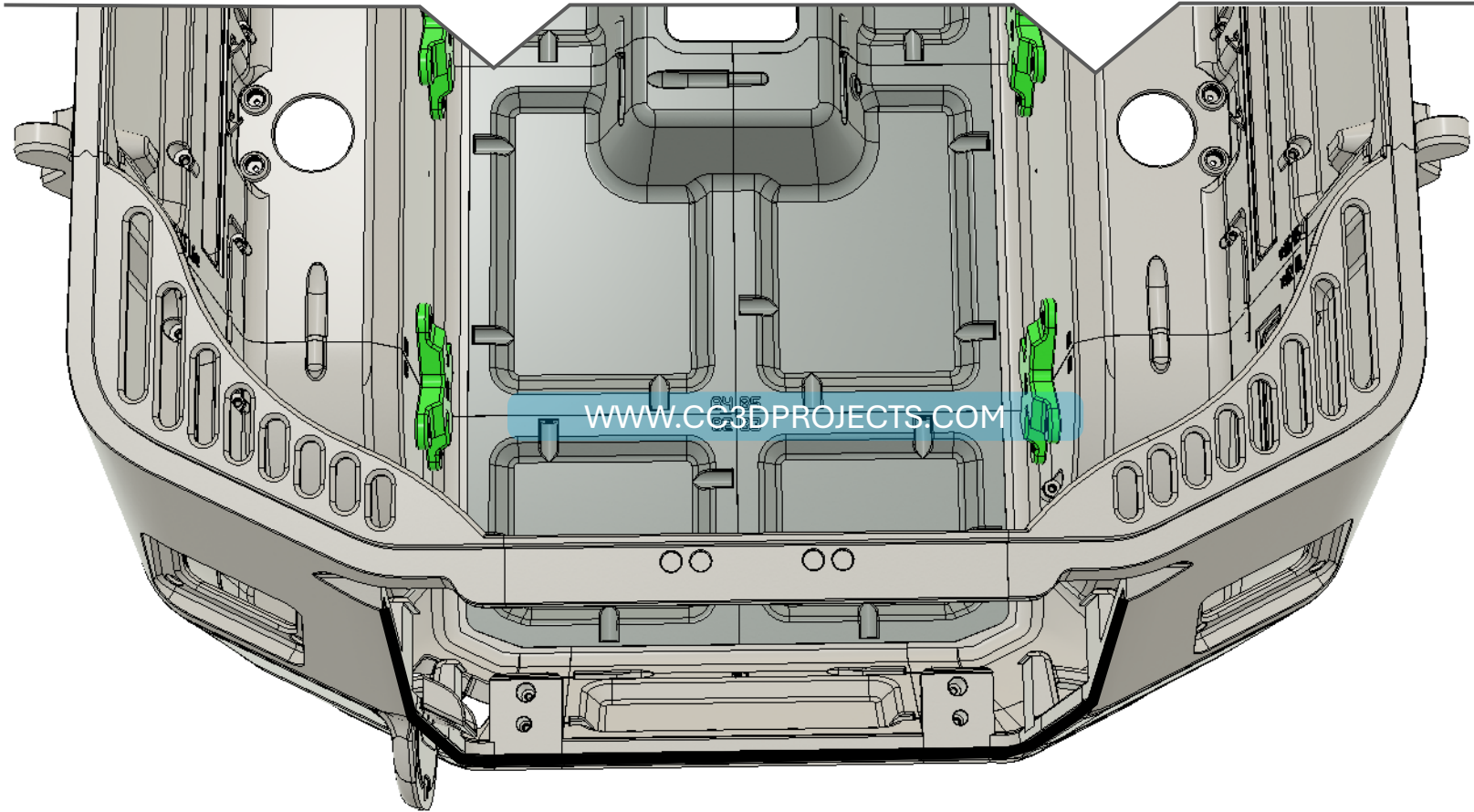

ALL MATERIAL PRODUCED AND PROVIDED HAS BEEN CONCEIVED, AUTHORED AND PRODUCED BY ENRICO MAZZAROL - ALL RIGHTS RESERVED.



# FILAMENT DOOR GASKETS



## SEALING THE FILAMENT COMPARTMENT DOORS!

EACH FILAMENT DOOR HAS A 6 MM WIDE GROOVE—PERFECT FOR THE 6X3 MM GASKET.

CAREFULLY PRESS THE GASKET INTO THE GROOVE ON **BOTH DOORS**, MAKING SURE IT'S NICE AND EVEN ALL THE WAY AROUND. TAKE YOUR TIME—CLEAN EDGES MEAN A BETTER SEAL AND A MORE POLISHED LOOK!

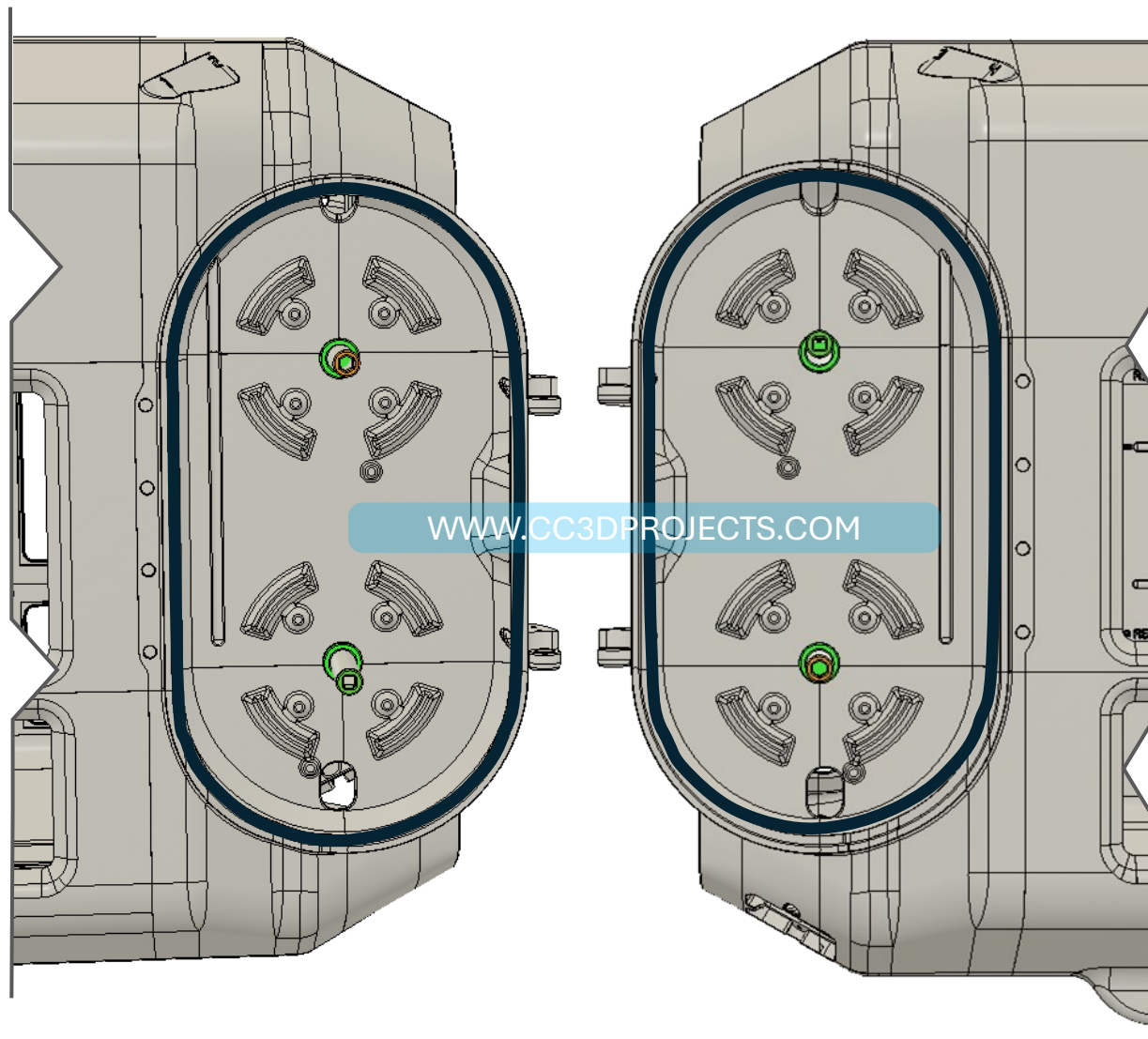

Buy me a coffee





# EXTERNAL SPOOL SUPPORTS

# ENCLOSURE A1



## LET'S INSTALL THE FOLDABLE SIDE SPOOL HOLDERS!

NOW IT'S TIME TO MOUNT THE FOLDABLE SPOOL HOLDERS ON THE SIDES.

HEADS UP—THERE ARE **TWO DIFFERENT TYPES**, MARKED WITH LETTERS, SO MAKE SURE YOU'RE PLACING THE RIGHT ONE IN THE RIGHT SPOT.

EACH HOLDER ALSO NEEDS A MAGNET—INSTALL IT USING **APPLICATOR B**. DON'T SKIP THIS STEP, OR THEY WON'T STAY IN PLACE PROPERLY!

LOOKING GOOD—YOUR SPOOL GAME JUST LEVELED UP!

Buy me a coffee

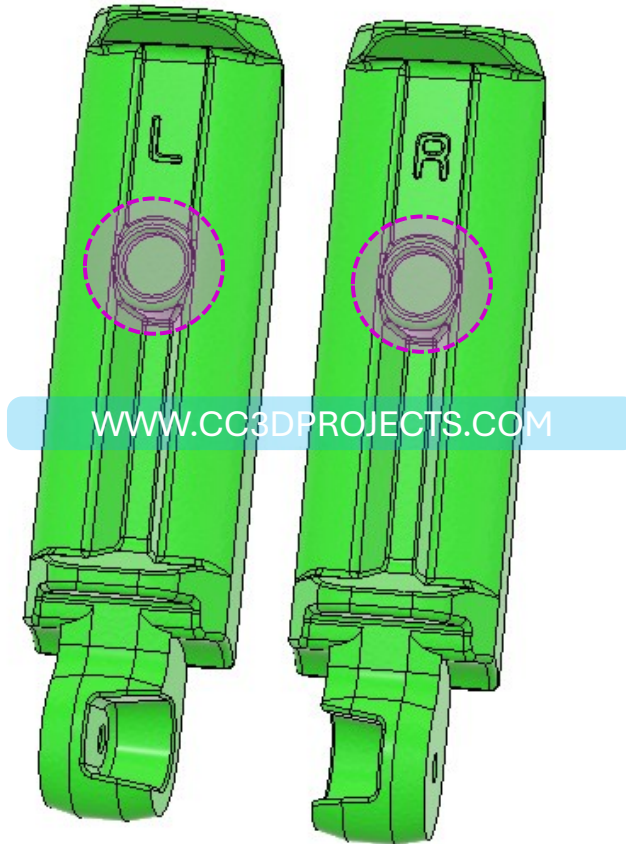

ALL MATERIAL PRODUCED AND PROVIDED HAS BEEN CONCEIVED, AUTHORED AND PRODUCED BY ENRICO MAZZAROL - ALL RIGHTS RESERVED.



# EXTERNAL SPOOL SUPPORTS

# ENCLOSURE A1



## LET'S INSTALL THE FOLDABLE SIDE SPOOL HOLDERS!

TIME TO MOUNT THE FOLDABLE SPOOL HOLDERS ON THE ENCLOSURE SIDES.

REMEMBER—THERE ARE **TWO DIFFERENT TYPES**, MARKED WITH LETTERS, SO MAKE SURE EACH ONE GOES IN THE CORRECT SPOT.

EACH HOLDER ALSO NEEDS A MAGNET—INSTALL IT USING **APPLICATOR B**. DON'T SKIP IT!

HOLD EACH SPOOL HOLDER **PARALLEL TO THE SIDE WALL** OF THE ENCLOSURE AS YOU INSERT IT.

ONCE IN PLACE, GIVE IT A TEST: USE THE FINGER NOTCH TO **ROTATE IT 90 DEGREES DOWNWARD**—SMOOTH AND EASY!

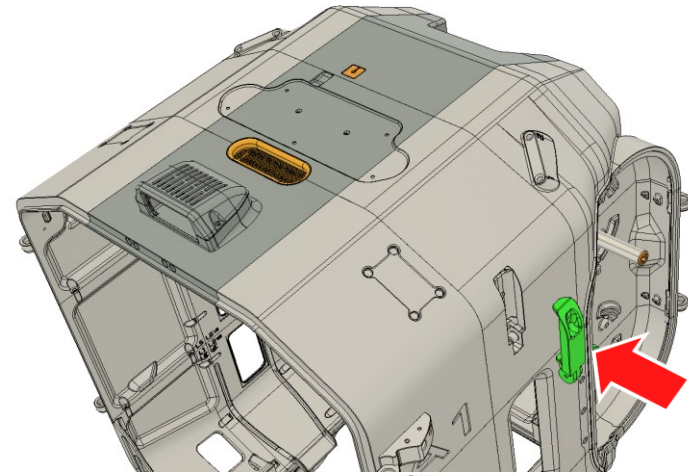
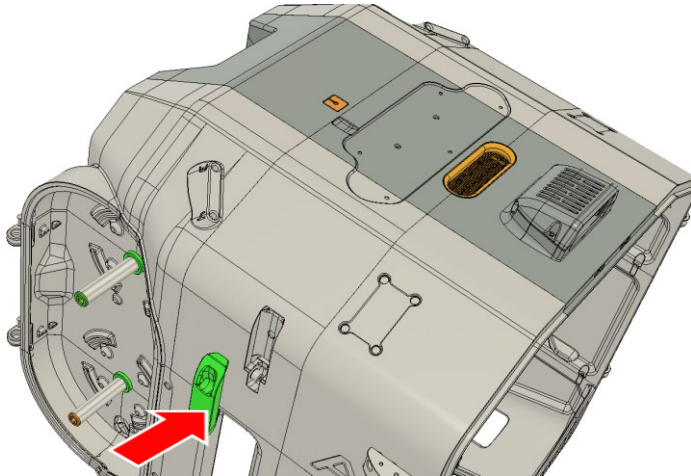

[WWW.CC3DPROJECTS.COM](http://WWW.CC3DPROJECTS.COM)

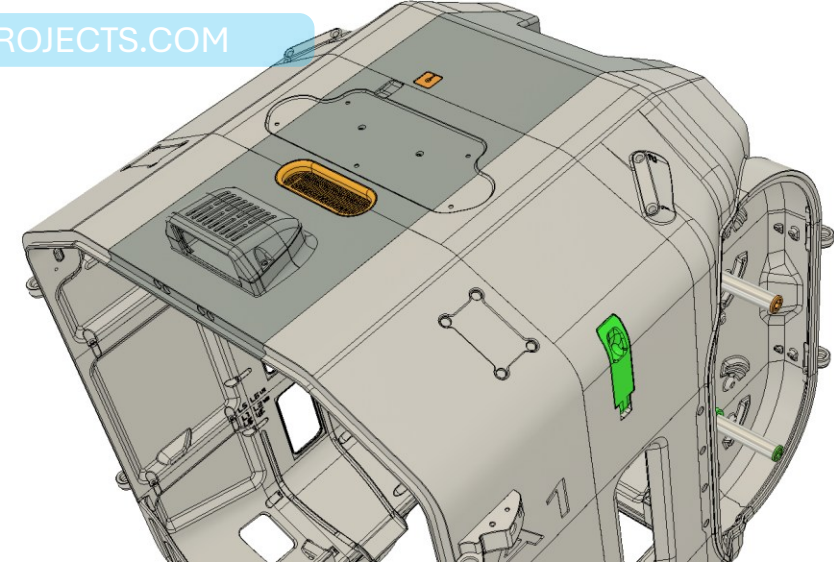
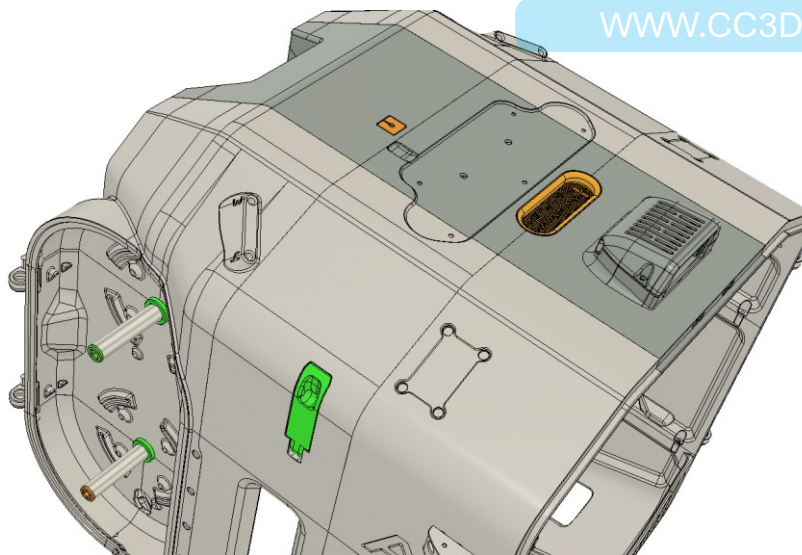

ALL MATERIAL PRODUCED AND PROVIDED HAS BEEN CONCEIVED, AUTHORED AND PRODUCED BY ENRICO MAZZAROL - ALL RIGHTS RESERVED.



# EXTERNAL SPOOL SUPPORTS

# ENCLOSURE A1



### SCREWS? OPTIONAL!

FROM WHAT I'VE SEEN, SCREWS **SHOULDN'T BE NECESSARY** FOR THE SPOOL HOLDERS—THEY STAY IN PLACE JUST FINE WITHOUT THEM.

BUT IF YOU'D LIKE SOME EXTRA SECURITY, FEEL FREE TO USE THE INDICATED SCREW HOLES.

THERE'S ALSO A SMALL HOLE IN THE STRUCTURE THAT LINES UP WITH THE HOLDER—SUPER HANDY FOR REMOVING IT LATER. JUST INSERT A SCREWDRIVER INTO THE HOLE AND **PUSH THE HOLDER OUT WHILE IT'S IN THE CLOSED POSITION**. EASY AND CLEAN!

Buy me a coffee

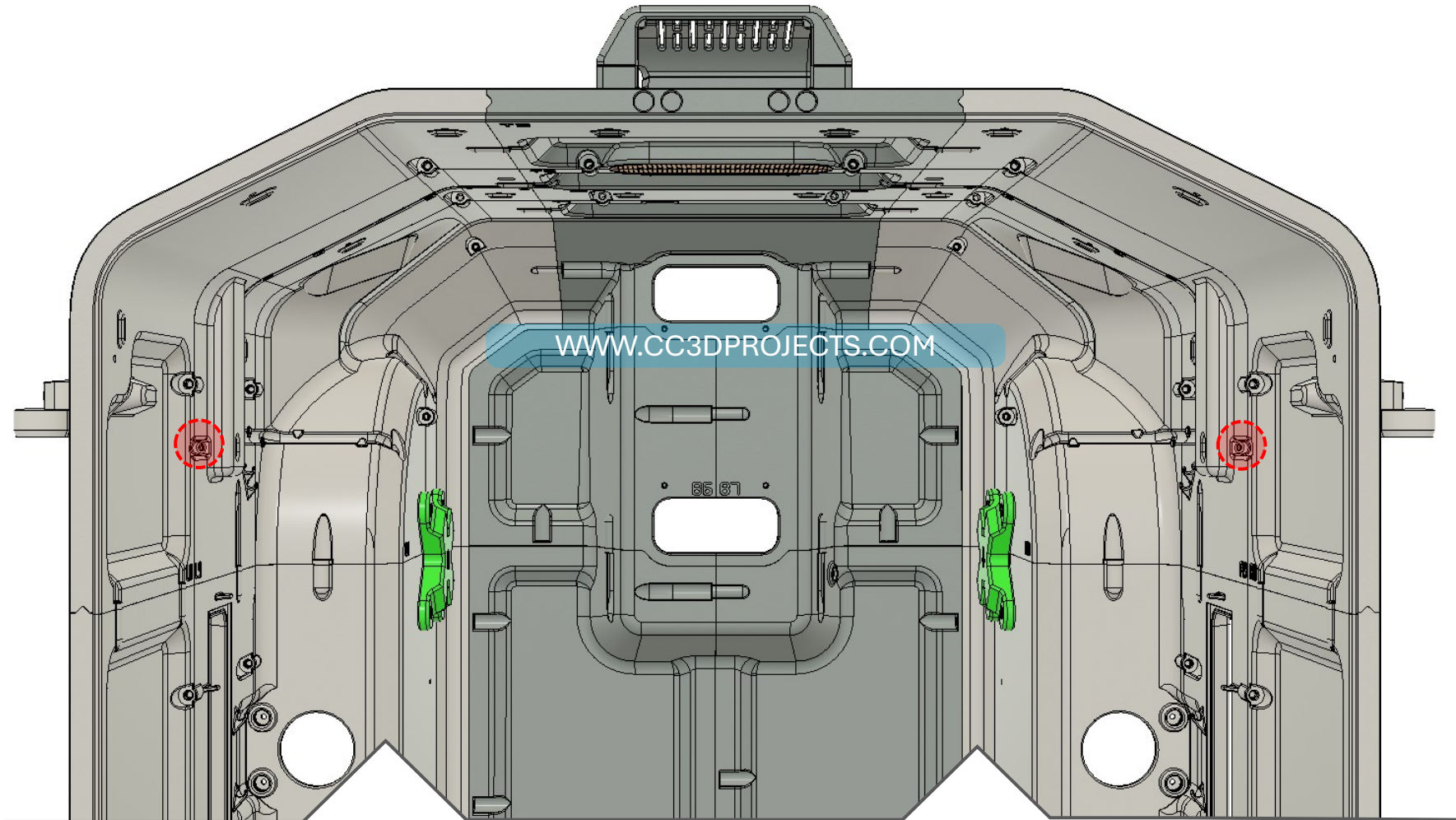

ALL MATERIAL PRODUCED AND PROVIDED HAS BEEN CONCEIVED, AUTHORED AND PRODUCED BY ENRICO MAZZAROL - ALL RIGHTS RESERVED.



# AMS LITE INSTALLATION

# ENCLOSURE A1



## LET'S START ASSEMBLING THE AMS LITE SECTION!

FIRST THINGS FIRST—GRAB THE SCREWS YOU SAVED EARLIER AND **SECURE THE ELECTRONICS BOARD ONTO THE NEW SUPPORT**. LINE IT UP CAREFULLY, SCREW IT DOWN, AND MAKE SURE IT'S SNUG BUT NOT OVERTIGHTENED. NICE AND STEADY—THIS LITTLE BOARD'S GOT AN IMPORTANT JOB TO DO!

Buy me a coffee

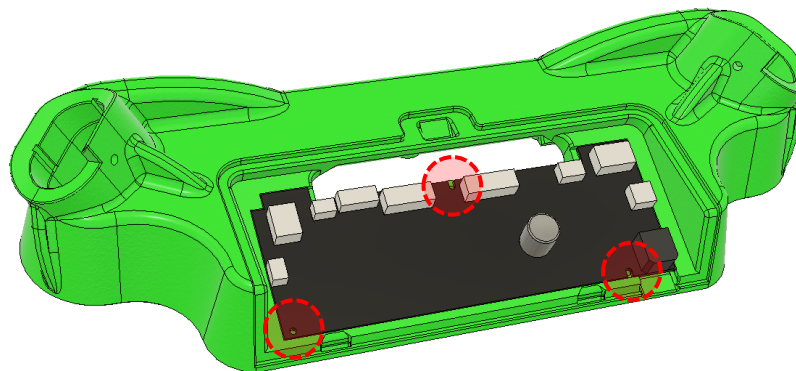

[WWW.CC3DPROJECTS.COM](http://WWW.CC3DPROJECTS.COM)

1-2 HEAD

3-4 HEAD

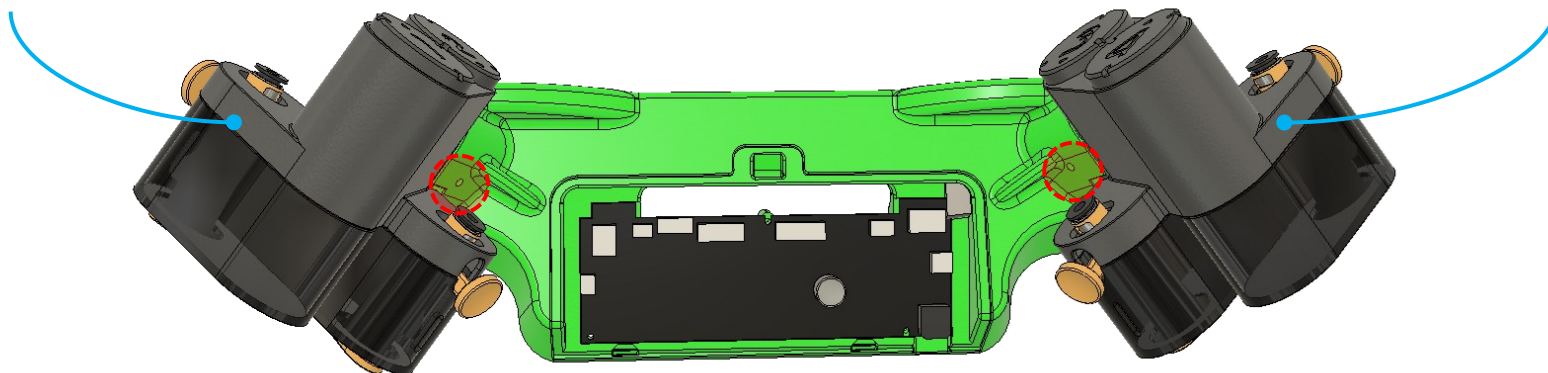

## MOUNT THE AMS HEADS!

NOW IT'S TIME TO INSTALL THE AMS HEADS, JUST LIKE SHOWN IN THE DIAGRAM.

USE **TWO SELF-TAPPING SCREWS** FOR EACH HEAD, FIXING THEM THROUGH THE INDICATED HOLES.

**IMPORTANT:** MAKE SURE THE SCREWS AREN'T TOO LONG—USING THE WRONG LENGTH COULD DAMAGE OR CUT THE INTERNAL WIRES OF THE HEADS.

TAKE IT SLOW, DOUBLE-CHECK, AND YOUR AMS HEADS WILL BE LOCKED IN SAFE AND SOUND!



# AMS LITE INSTALLATION

# ENCLOSURE A1



**LET'S CONNECT THE AMS HEADS!**

NOW PLUG IN THE CABLES JUST LIKE YOU SEE IN THE DIAGRAM:

**BLACK ON THE LEFT, WHITE ON THE RIGHT.** EASY TO REMEMBER!

MAKE SURE THE CONNECTORS ARE FULLY SEATED—BUT DON'T FORCE THEM. A GENTLE PUSH DOES THE TRICK!

Buy me a coffee

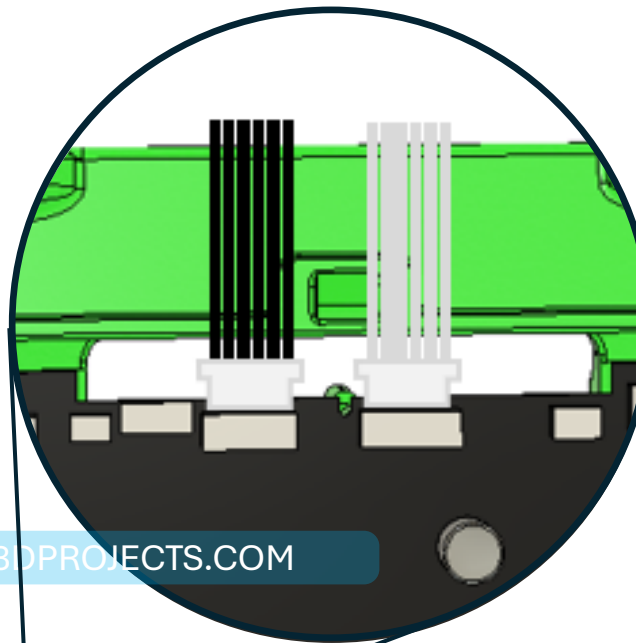

WWW.CC3DPROJECTS.COM

1-2 HEAD

3-4 HEAD

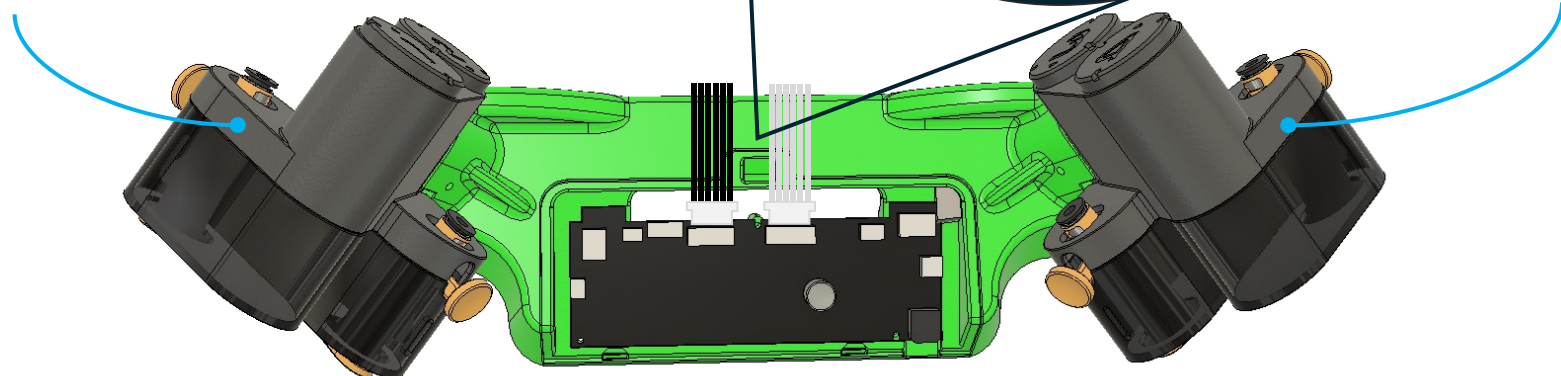

ALL MATERIAL PRODUCED AND PROVIDED HAS BEEN CONCEIVED, AUTHORED AND PRODUCED BY ENRICO MAZZAROL - ALL RIGHTS RESERVED.



**LET'S MOUNT THE HEAD ASSEMBLY TO THE ENCLOSURE!**

TIME TO FIX THE HEAD ASSEMBLY ONTO THE ENCLOSURE.

USE YOUR **STANDARD SCREWS** AND SECURE IT THROUGH THE **FIVE HIGHLIGHTED HOLES**, JUST LIKE SHOWN IN THE IMAGE. MAKE SURE EVERYTHING IS ALIGNED PROPERLY BEFORE TIGHTENING—ONCE IT'S IN, IT SHOULD FEEL NICE AND SOLID!

Buy me a coffee

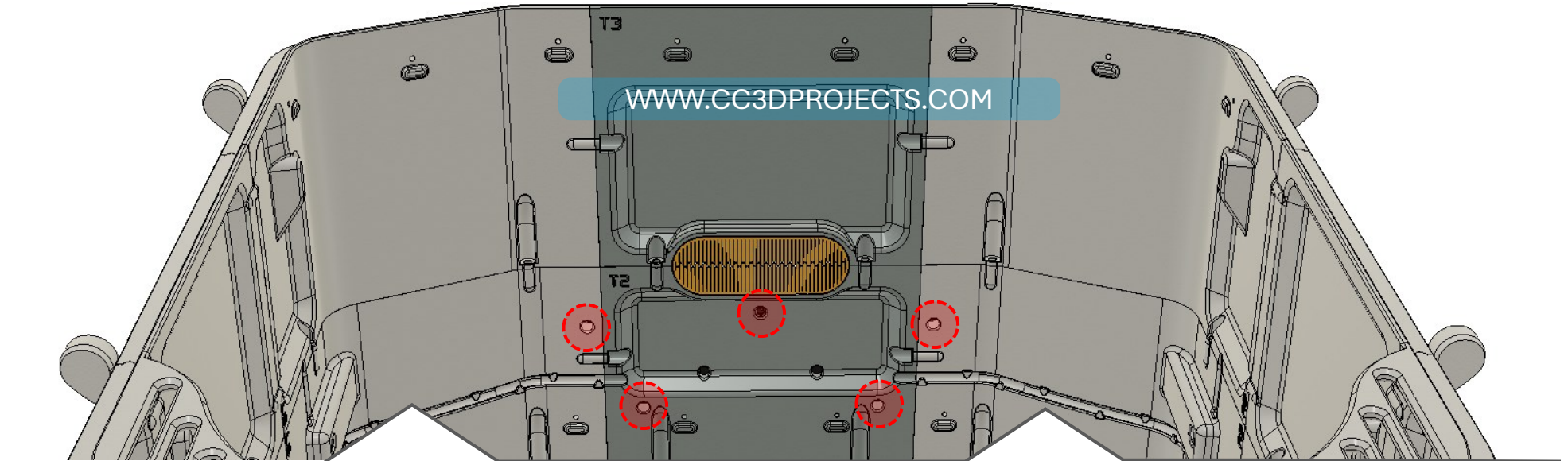
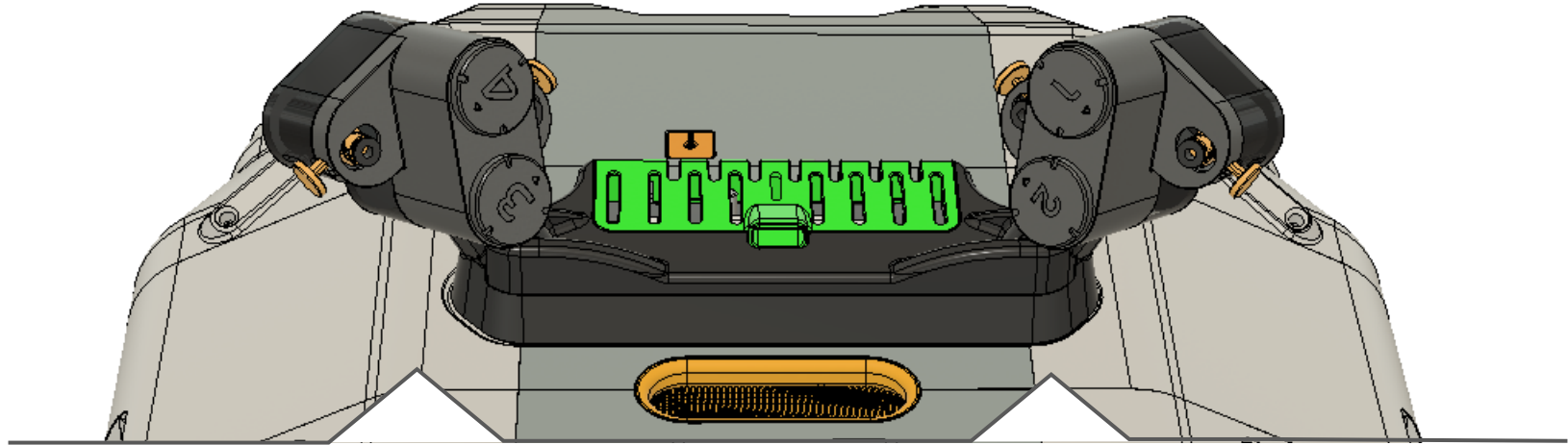



# ENCLOSURE – DRAWER MATING

**WHEW, THE HEAVIEST PART IS DONE!**

NOW LET'S PLACE THE ENCLOSURE ONTO THE DRAWER YOU'VE CHOSEN.

**GENTLY** LOWER THE ENCLOSURE DOWN ONTO THE DRAWER UNTIL THE **INTERNAL HOOKS** REST SECURELY ON THE TOP STRUCTURE OF THE DRAWER.

TAKE IT SLOW—NO NEED TO RUSH. ONCE IT'S SITTING RIGHT, YOU'LL FEEL IT CLICK INTO PLACE LIKE IT BELONGS THERE. BECAUSE IT DOES!

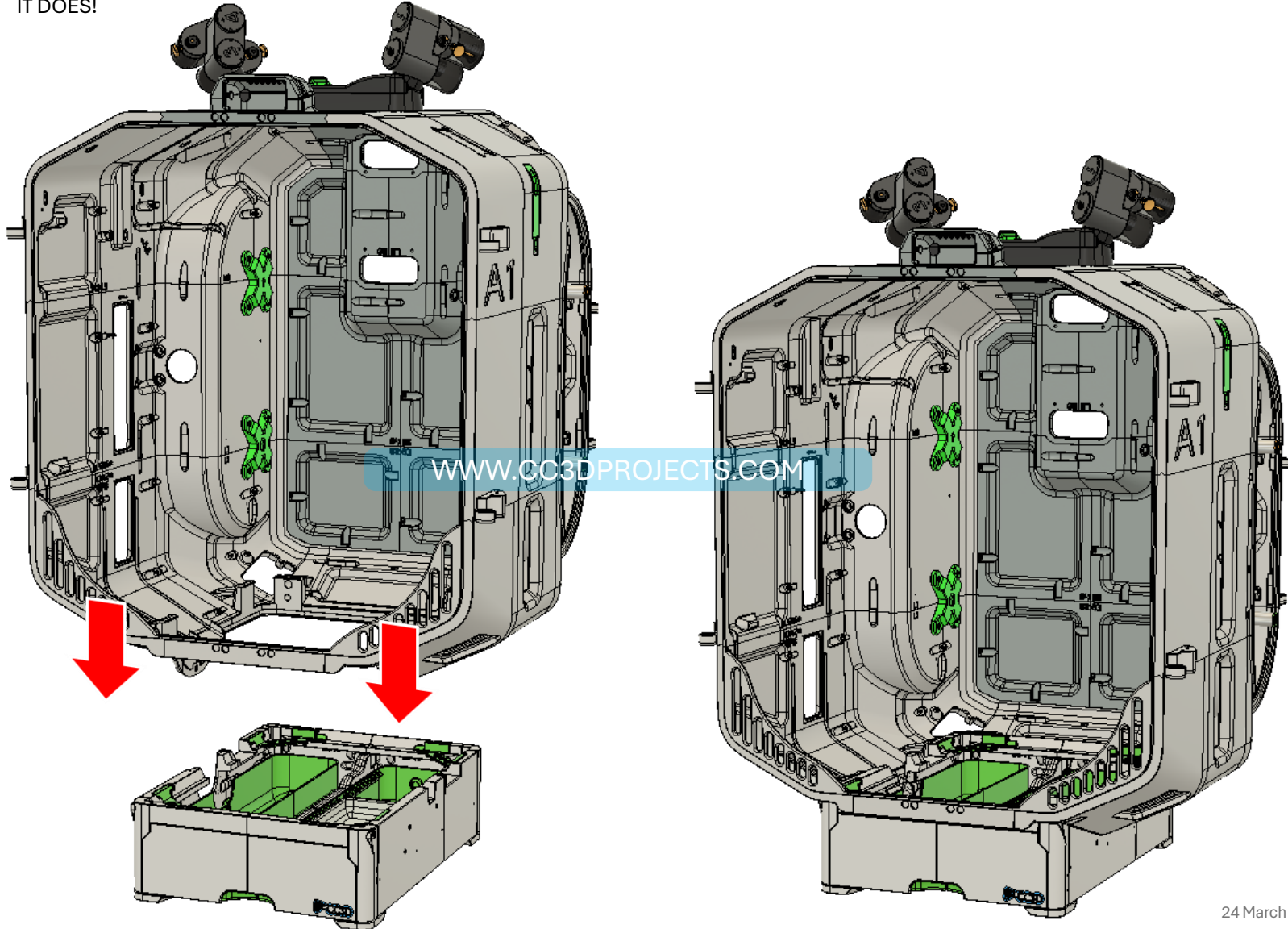

Buy me a coffee





# AIR PIPES

# ENCLOSURE A1



**NO TIME TO WASTE—LET’S ASSEMBLE THE AIR DUCTS FROM THE POLYDRYER!**  
BEFORE WE GET INTO THE TUBING, WE’VE GOT SOME MAGNETS TO INSTALL.  
CHECK THE IMAGE CAREFULLY—IT SHOWS **WHICH APPLICATOR TO USE FOR EACH MAGNET.**  
FOLLOW IT CLOSELY, AND YOU’LL BE ON TRACK IN NO TIME!  
MAGNETS FIRST, AIRFLOW NEXT. LET’S KEEP IT MOVIN’!

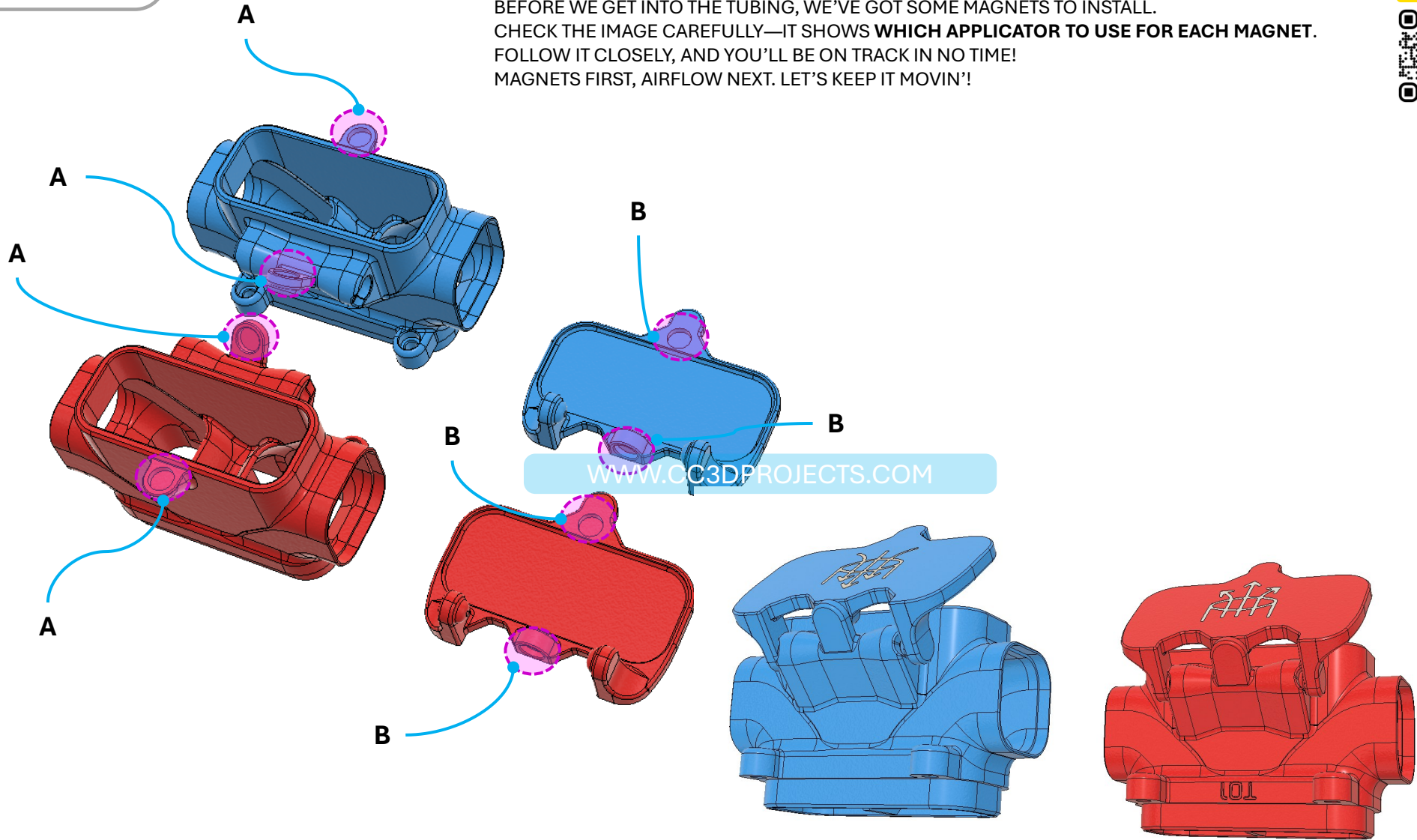

ALL MATERIAL PRODUCED AND PROVIDED HAS BEEN CONCEIVED, AUTHORED AND PRODUCED BY ENRICO MAZZAROL - ALL RIGHTS RESERVED.

## AIR PIPES – HOT AIR

## ENCLOSURE A1



**SNAP IN THE TUBES AND LOCK 'EM DOWN!**  
NOW IT'S TIME TO CONNECT ALL THE AIR DUCTS.

**SNAP EACH TUBE INTO PLACE**, MAKING SURE THEY FIT SNUGLY. ONCE THEY'RE IN, ADD A FEW DROPS OF FAST-DRYING GLUE TO KEEP EVERYTHING SECURE.

**IMPORTANT:** BEFORE GLUING, DOUBLE-CHECK FOR ANY BURRS OR DEBRIS LEFT OVER FROM SUPPORT REMOVAL—CLEAN CONNECTIONS MAKE FOR SMOOTH AIRFLOW!

Buy me a coffee

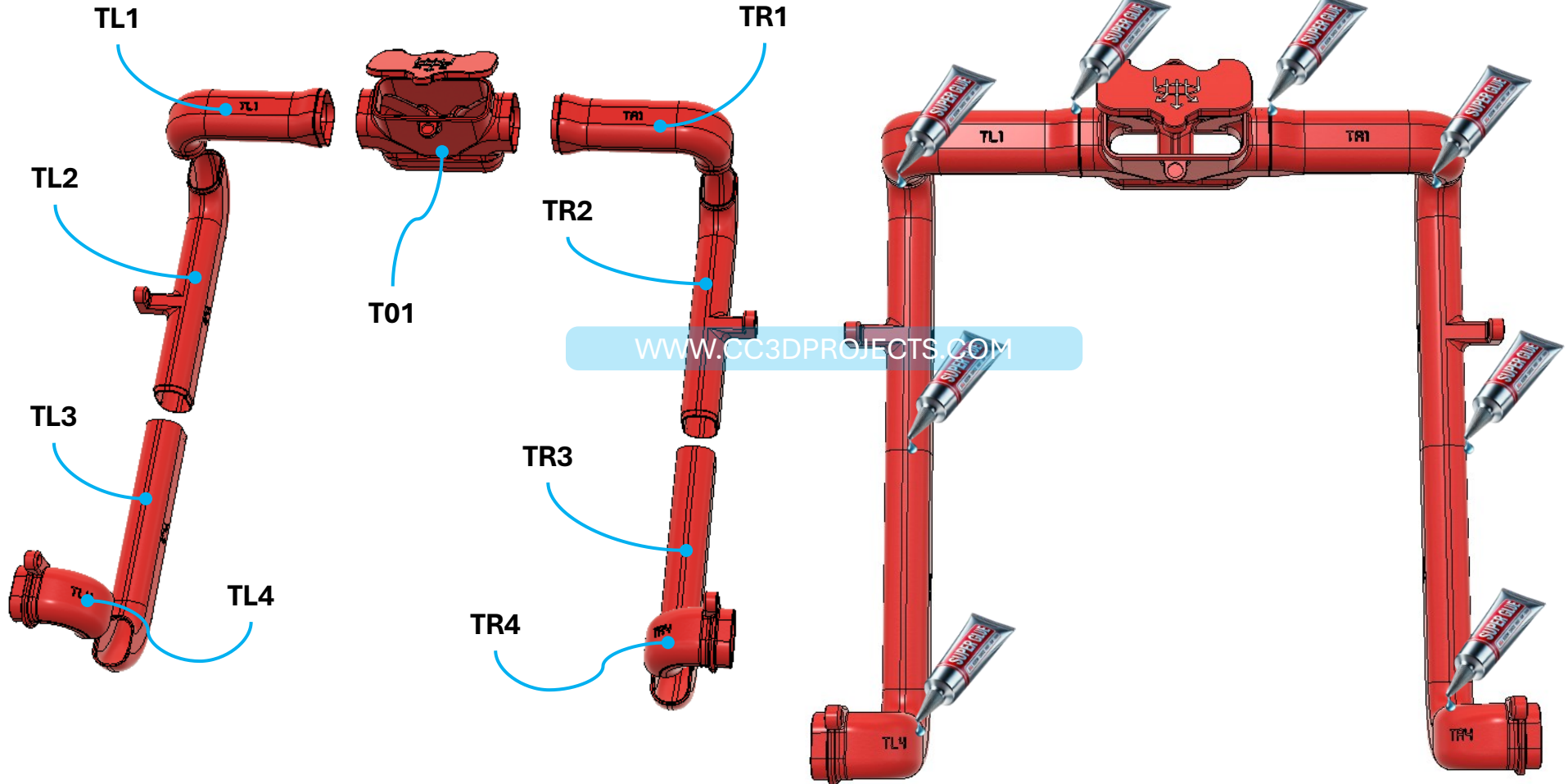

## AIR PIPES – HOT AIR

## ENCLOSURE A1



### INSTALL THE MAIN DUCT ASSEMBLY INTO THE STRUCTURE

GENTLY INSERT THE DUCT SYSTEM INTO THE ENCLOSURE.

START BY SLIDING THE **BOTTOM TUBES IN FIRST**, THEN GUIDE THE **CENTER SECTION INTO THE CENTRAL HOLE**. TAKE YOUR TIME—NO NEED TO FORCE IT.

ONCE EVERYTHING IS IN POSITION, **SECURE THE ASSEMBLY USING SCREWS IN THE HIGHLIGHTED HOLES**.

NICE AND EASY—JUST LIKE PUTTING THE LAST PIECE IN A PUZZLE!



Buy me a coffee

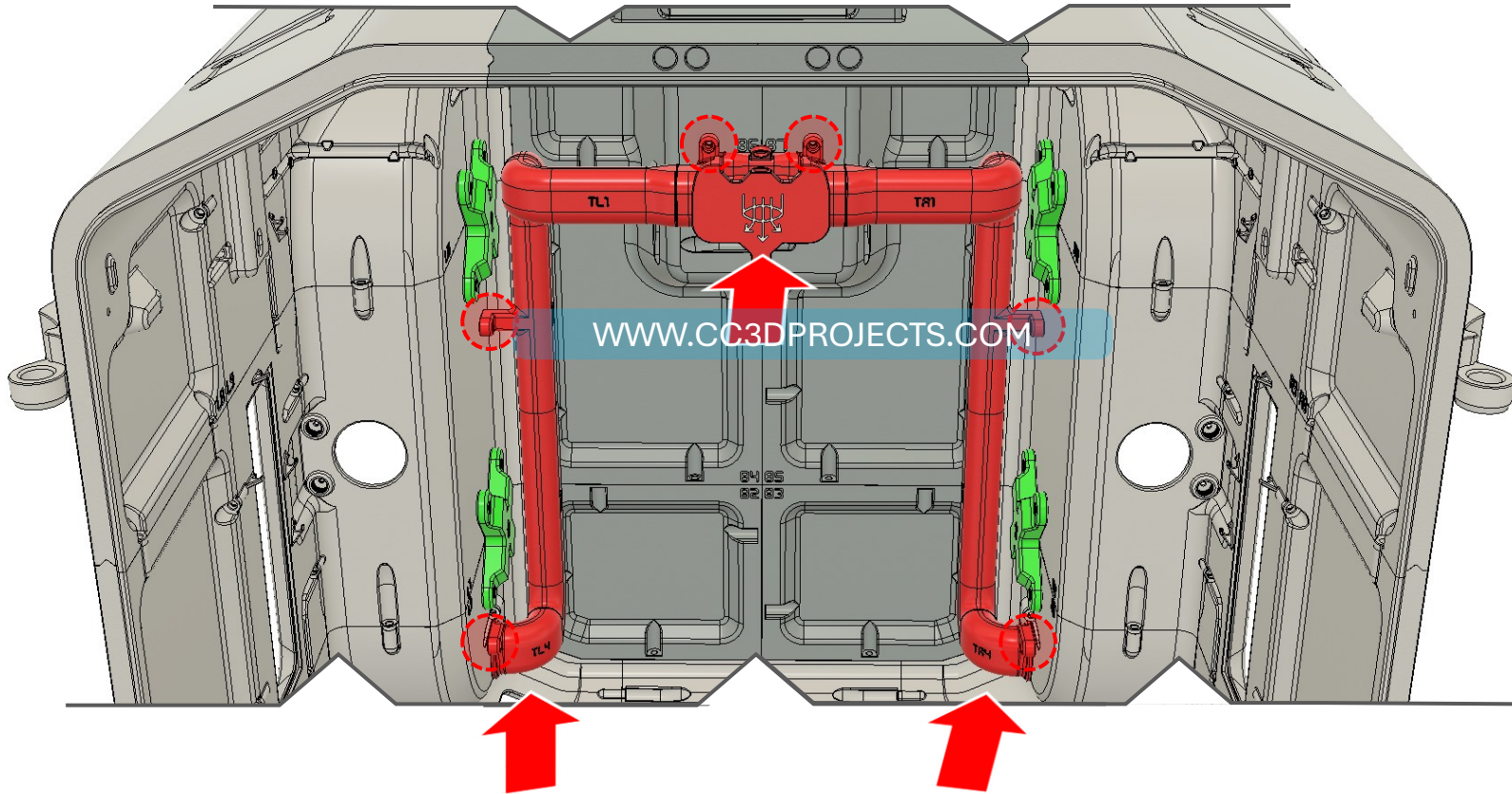

# AIR PIPES – COLD AIR

# ENCLOSURE A1



**LET'S INSTALL THE DRYER INTAKE PIPES!**  
START BY INSERTING THE TUBES ON **BOTH THE RIGHT AND LEFT SIDES**.  
PUSH THEM A LITTLE DEEPER INTO THE HOLES THAN USUAL—THIS GIVES YOU SOME EXTRA ROOM TO WORK WITH IN THE CENTER. GETHER!

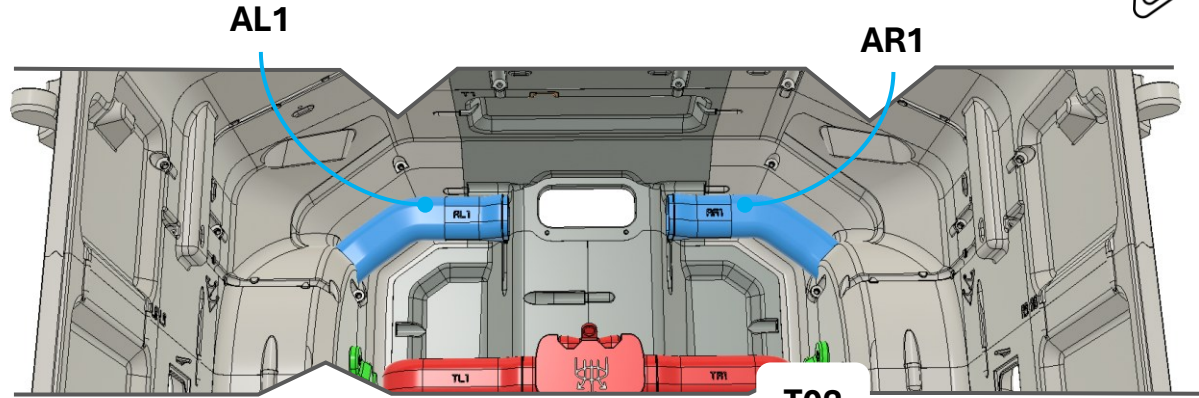

NEXT, SLIDE IN THE **CENTER PIECE** AND **SECURE IT WITH SCREWS**.  
FINALLY, **GENTLY CONNECT THE SIDE PIPES TO THE CENTER PIECE**, MAKING SURE EVERYTHING LINES UP SMOOTHLY.!

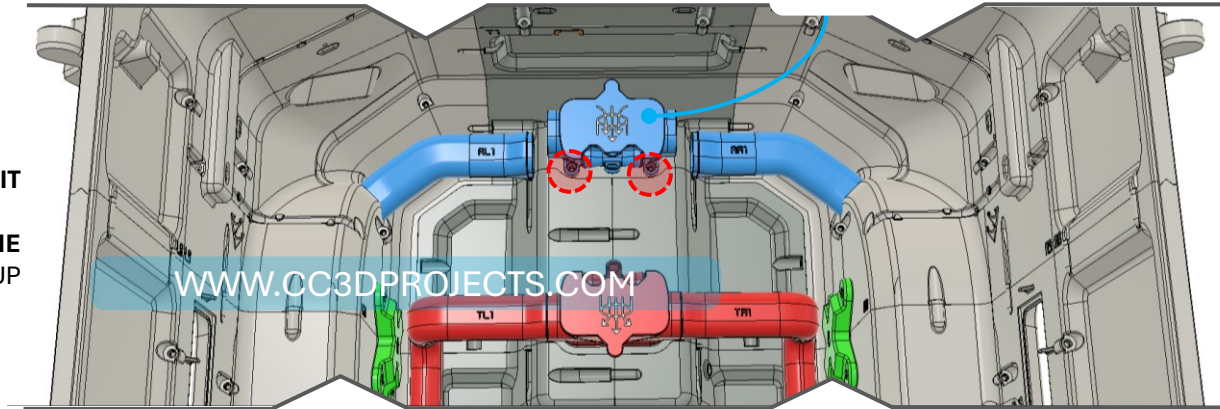

ONCE IT'S ALL IN PLACE, ADD A FEW DROPS OF **FAST-DRYING GLUE** TO LOCK IT ALL TOGETHER.  
NICE JOB—YOUR AIRFLOW SYSTEM IS REALLY COMING TOGETHER!

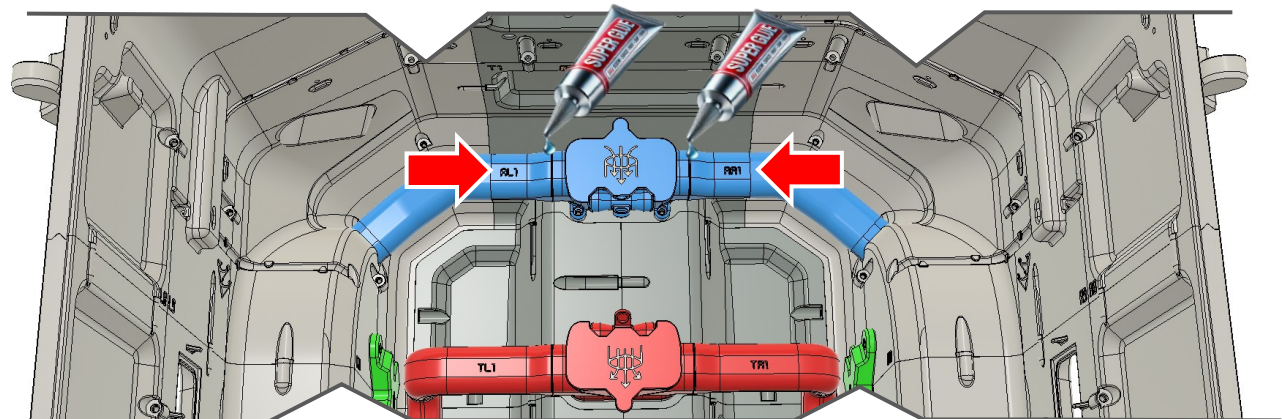

ALL MATERIAL PRODUCED AND PROVIDED HAS BEEN CONCEIVED, AUTHORED AND PRODUCED BY ENRICO MAZZAROL - ALL RIGHTS RESERVED.



# TOP REINFORCEMENTS

# ENCLOSURE A1



Buy me a coffee



**TIME TO ADD SOME REINFORCEMENTS!**  
LET'S GIVE YOUR ENCLOSURE SOME EXTRA STRENGTH.

WE'RE INSTALLING STRUCTURAL SUPPORTS NOW, SO **PAY CLOSE ATTENTION TO THE PART CODES**—EACH ONE HAS ITS PROPER PLACE AND GETTING THEM RIGHT MAKES EVERYTHING STURDIER AND CLEANER.

LINE THEM UP, DOUBLE-CHECK THE CODES, AND LET'S LOCK THIS BUILD DOWN SOLID!

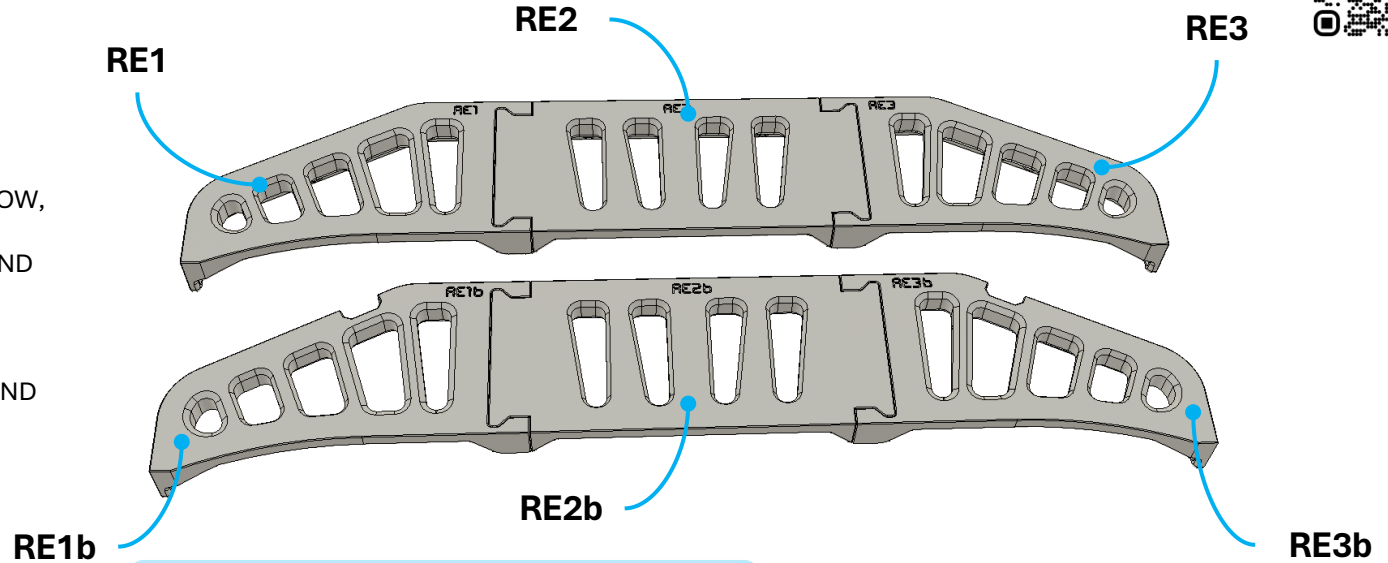

[WWW.CC3DPROJECTS.COM](http://WWW.CC3DPROJECTS.COM)

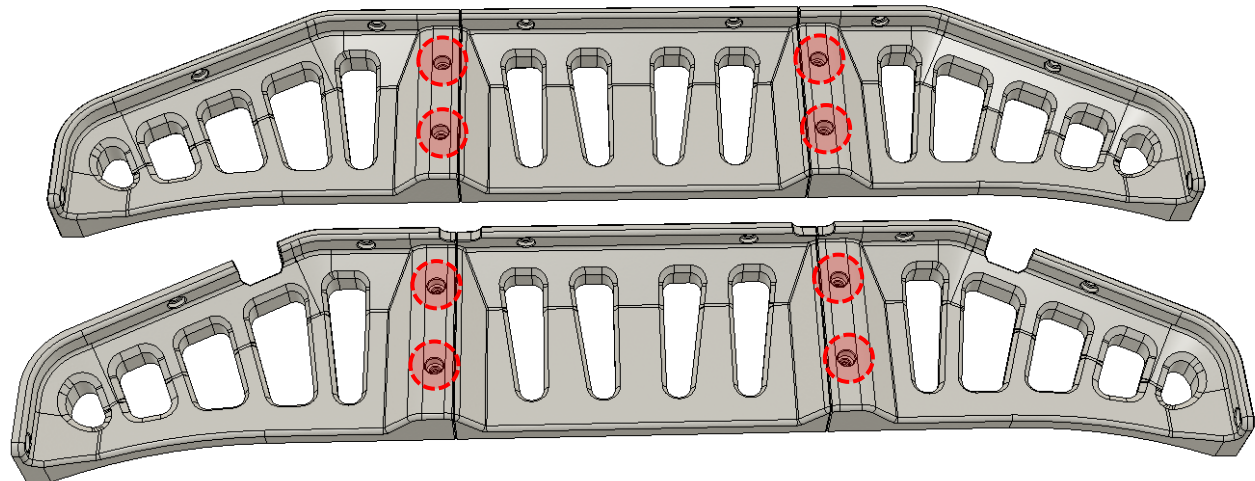

ALL MATERIAL PRODUCED AND PROVIDED HAS BEEN CONCEIVED, AUTHORED AND PRODUCED BY ENRICO MAZZAROL - ALL RIGHTS RESERVED.



# TOP REINFORCEMENTS

# ENCLOSURE A1



LET'S INSTALL THE REAR SUPPORT! TIME TO ADD THE BACK SUPPORT—THE ONE WITH THE CUTOUTS DESIGNED FOR OPTIONAL LED STRIPS. SLIDE IT INTO PLACE CAREFULLY, MAKING SURE THE OPENINGS LINE UP AS INTENDED. IF YOU'RE PLANNING TO ADD LIGHTING LATER, THIS PIECE HAS YOU COVERED! ONCE ALIGNED, SECURE IT AS SHOWN—AND BOOM, YOUR ENCLOSURE JUST GOT SMARTER AND STURDIER.

Buy me a coffee



ALL MATERIAL PRODUCED AND PROVIDED HAS BEEN CONCEIVED, AUTHORED AND PRODUCED BY ENRICO MAZZAROL - ALL RIGHTS RESERVED.

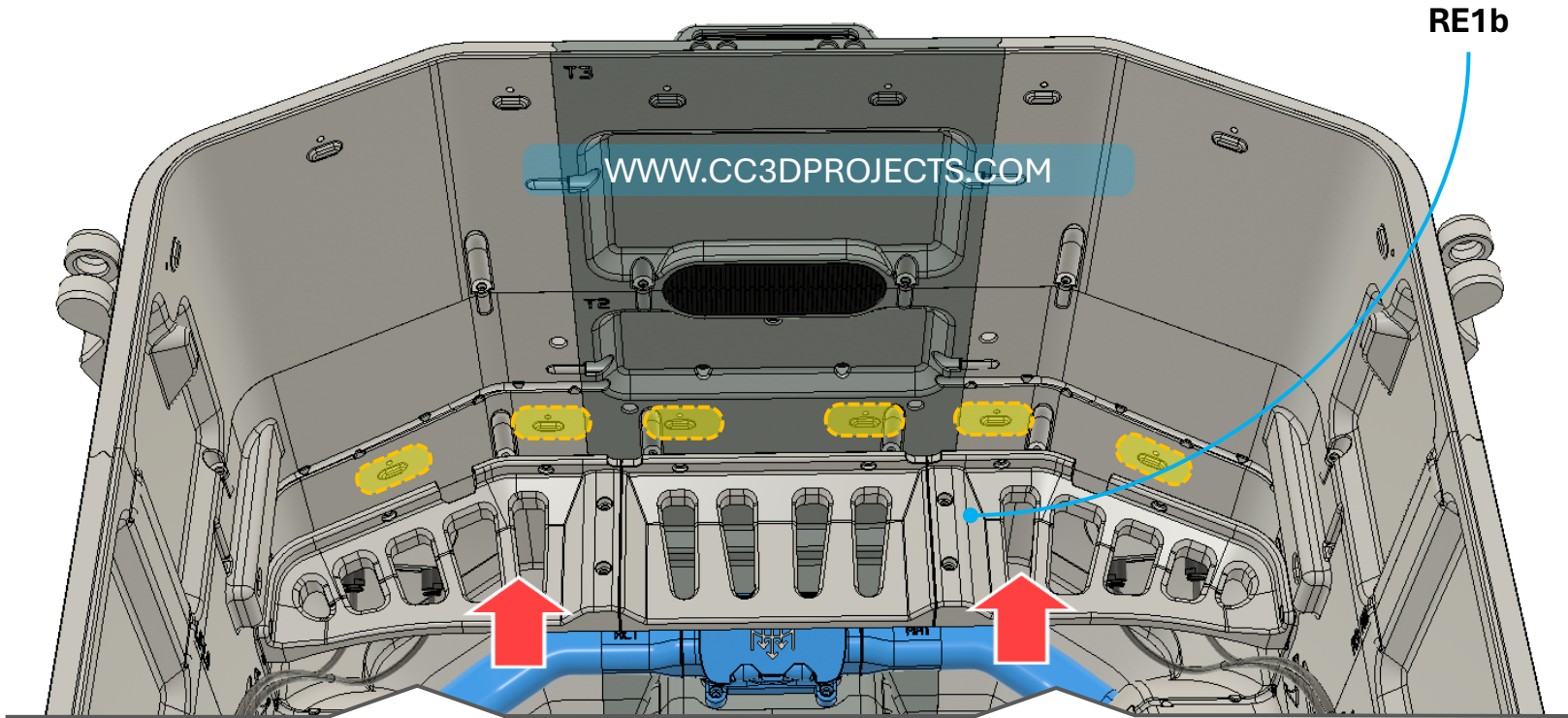

## TOP REINFORCEMENTS

## ENCLOSURE A1



### TIME TO LOCK IT IN!

ONCE THE BACK SUPPORT IS ALIGNED USING THE SLOTS, START TIGHTENING THE SCREWS—**BEGINNING FROM THE CENTER AND WORKING YOUR WAY OUT.**

NOW, YOU MIGHT NOTICE THERE'S A **2.5 MM GAP ON EACH SIDE** OF THE SUPPORT.

LET US STOP YOU RIGHT THERE: **THAT'S NOT A DEFECT—IT'S ON PURPOSE!** 😊

THAT LITTLE GAP HELPS TENSION THE STRUCTURE, KEEPING EVERYTHING SOLID AND PROPERLY SHAPED.

IT ALSO HELPS ENSURE THE **FRONT DOORS STAY PERFECTLY ALIGNED.**

**SO GO AHEAD, TIGHTEN THOSE SIDE SCREWS... AND DON'T EVEN *THINK* ABOUT MESSAGING ME TO REPORT IT AS A FLAW. GOT IT? LOL** 😂

Buy me a coffee



ALL MATERIAL PRODUCED AND PROVIDED HAS BEEN CONCEIVED, AUTHORED AND PRODUCED BY ENRICO MAZZAROL - ALL RIGHTS RESERVED.

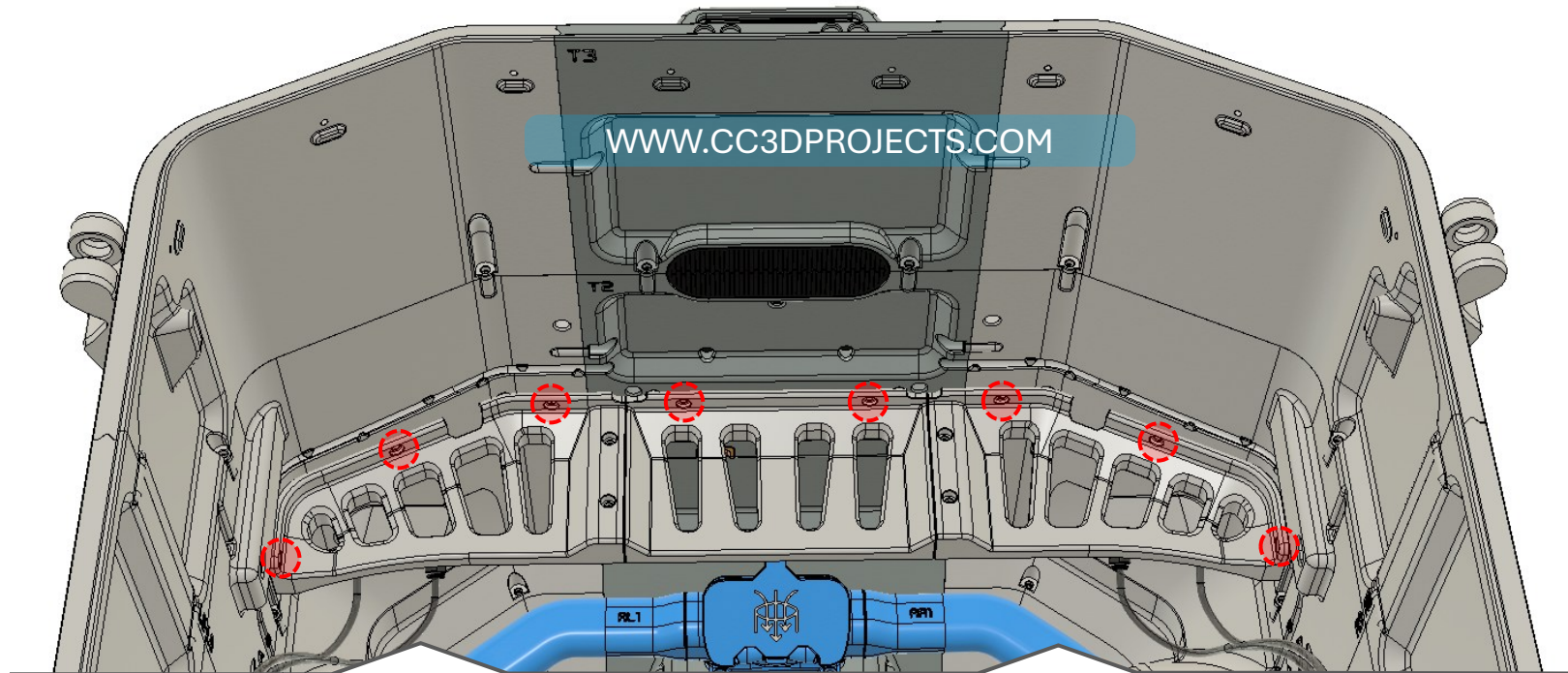



# TOP REINFORCEMENTS

**FOR MAXIMUM PRECISION—HERE’S WHERE THE LED SLOTS ARE!**

JUST TO BE EXTRA CLEAR, I’M POINTING OUT THE **CUTOUTS DESIGNED FOR LED STRIP INSTALLATION.**

IF YOU PLAN TO ADD LIGHTING LATER, THESE SLOTS WILL MAKE THE JOB SUPER EASY—JUST ROUTE THE STRIPS RIGHT THROUGH THEM!

NO GUESSWORK NEEDED, IT’S ALL SET UP FOR YOU! 😊



HOLE FOR LED STRIP PASSAGE

HOLE FOR LED STRIP PASSAGE

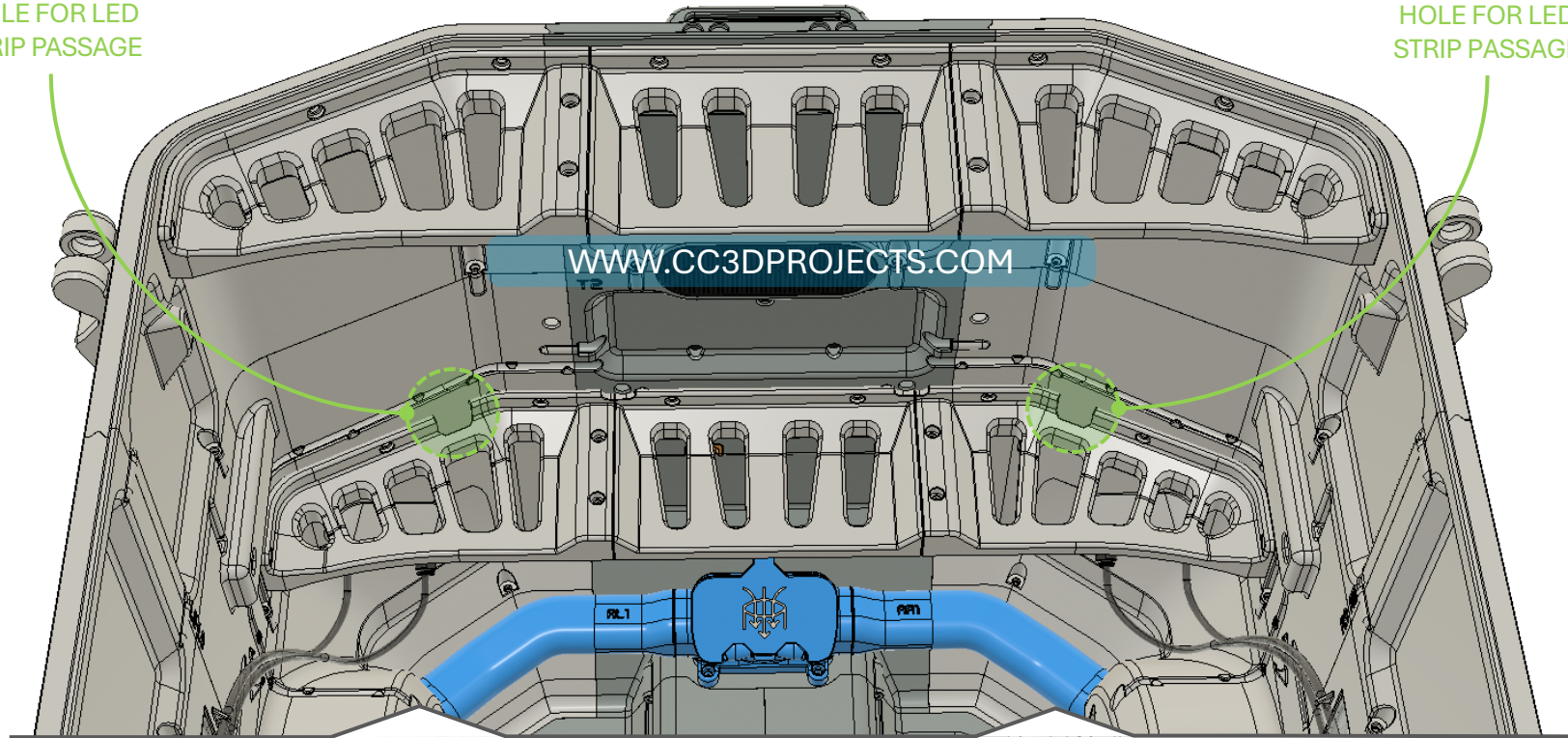

ALL MATERIAL PRODUCED AND PROVIDED HAS BEEN CONCEIVED, AUTHORED AND PRODUCED BY ENRICO MAZZAROL - ALL RIGHTS RESERVED.



# TOP REINFORCEMENTS

## LET'S INSTALL THE FRONT SUPPORT!

TIME TO REINFORCE THE FRONT SIDE—THIS PIECE HELPS LOCK EVERYTHING IN PLACE AND KEEPS YOUR ENCLOSURE SOLID. CAREFULLY POSITION IT, ENSURING EVERYTHING IS PROPERLY ALIGNED ONCE IT'S SET, SECURE IT WITH THE SCREWS, AND JUST LIKE THAT—YOUR ENCLOSURE IS STRONGER AND BETTER THAN EVER!

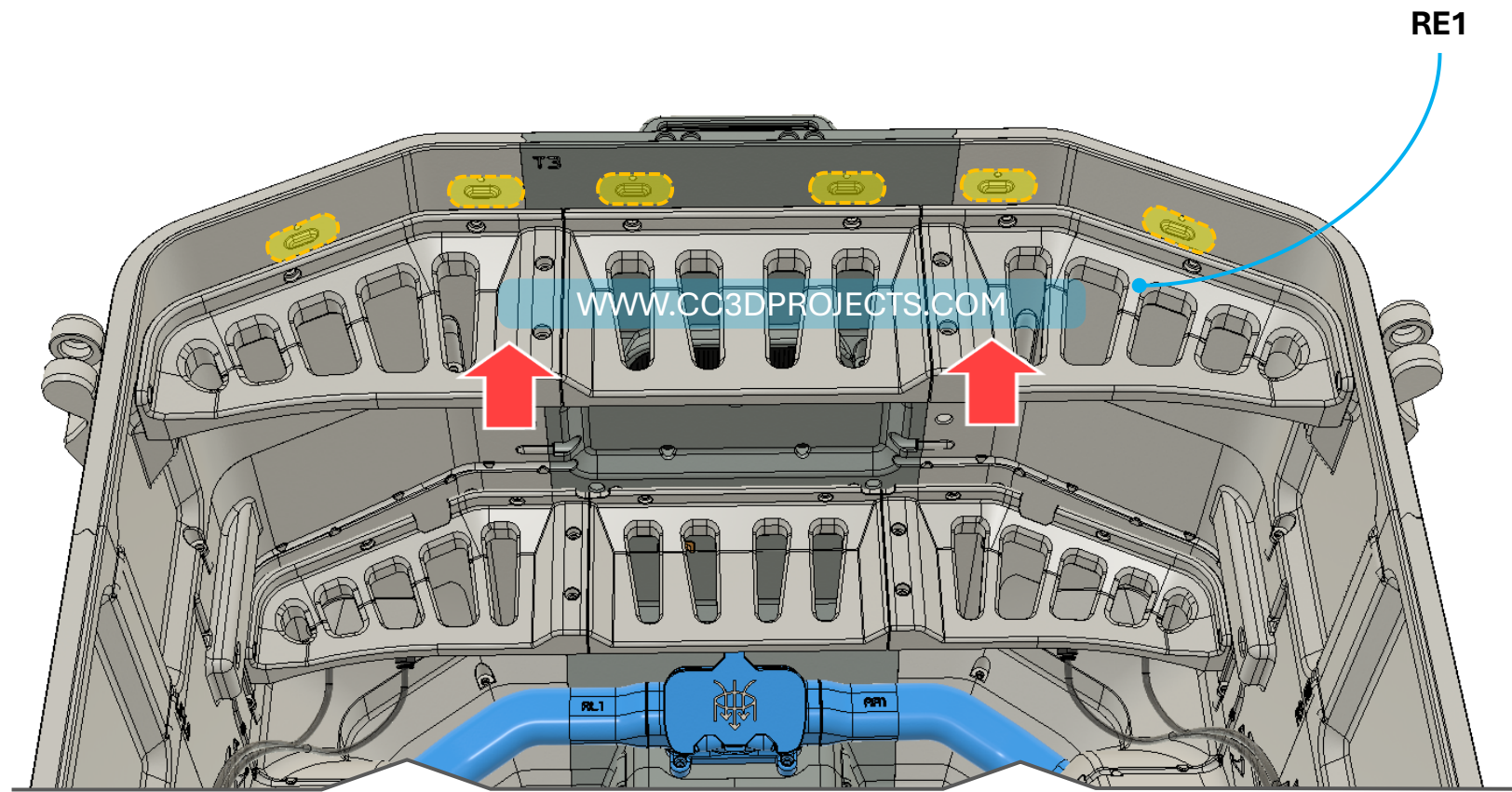

ALL MATERIAL PRODUCED AND PROVIDED HAS BEEN CONCEIVED, AUTHORED AND PRODUCED BY ENRICO MAZZAROL - ALL RIGHTS RESERVED.



# TOP REINFORCEMENTS

# ENCLOSURE A1



## LOCK IT DOWN—FRONT EDITION!

ONCE EVERYTHING’S ALIGNED, START **TIGHTENING THE SCREWS FROM THE CENTER OUTWARD**, JUST LIKE WITH THE REAR SUPPORT.

AND YEP, YOU’LL SEE A **2.5 MM GAP ON EACH SIDE** HERE TOO.

NOPE, STILL NOT A DEFECT. IT’S **TOTALLY INTENTIONAL!** 😏

THIS GAP KEEPS THE STRUCTURE UNDER JUST THE RIGHT AMOUNT OF TENSION, MAKING THE WHOLE BUILD MORE RIGID AND HELPING YOUR **FRONT DOORS LINE UP LIKE A DREAM.**

SO, TIGHTEN THOSE SIDE SCREWS WITH CONFIDENCE—AND DON’T EVEN *THINK* ABOUT SENDING A “HEY, IS THIS A DEFECT?” MESSAGE. I SEE YOU. LOL 😂

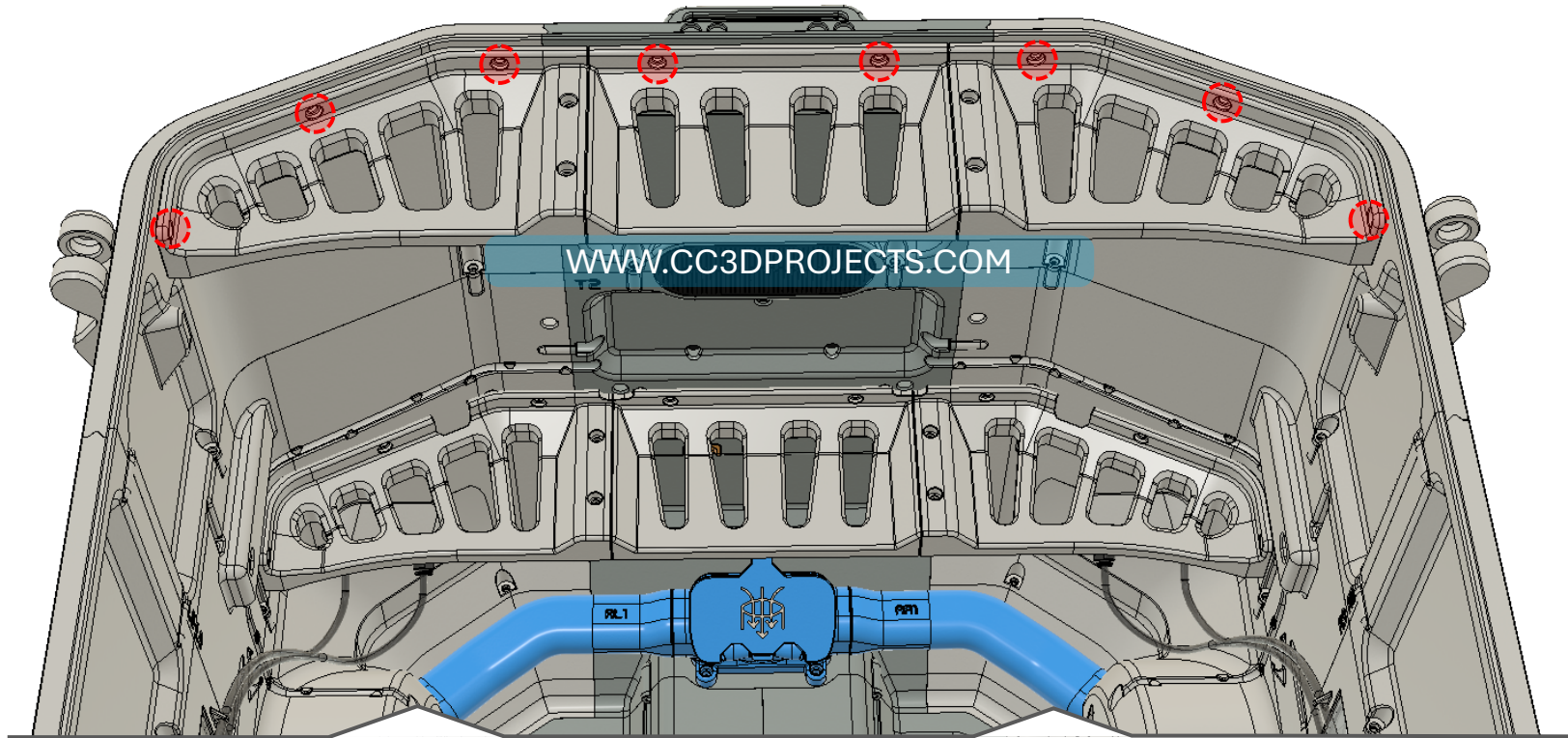

WWW.CC3DPROJECTS.COM

ALL MATERIAL PRODUCED AND PROVIDED HAS BEEN CONCEIVED, AUTHORED AND PRODUCED BY ENRICO MAZZAROL - ALL RIGHTS RESERVED.



# FILAMENT DOOR INSTALLATION

# ENCLOSURE A1



Buy me a coffee

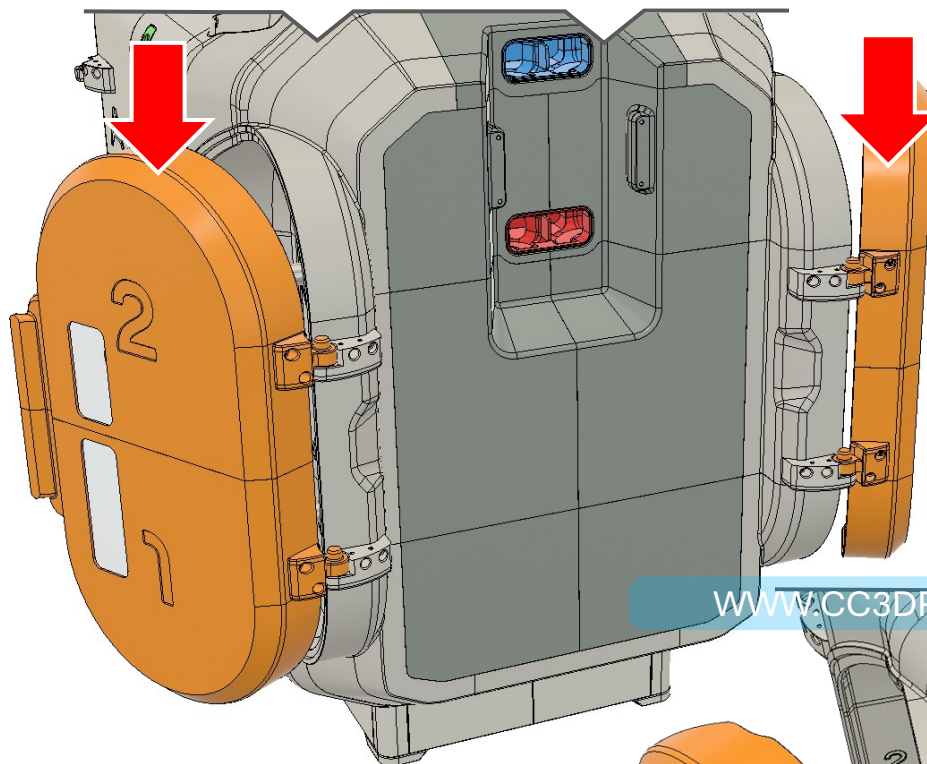

## LET'S INSTALL THE FILAMENT STORAGE DOORS!

NOW IT'S TIME TO MOUNT THE FILAMENT STORAGE DOORS. USE THE **MATCHING DOOR PIECES** THAT CORRESPOND TO THE HINGES ALREADY INSTALLED ON THE STRUCTURE. ALIGN THEM PROPERLY, THEN **SECURE EVERYTHING USING THE STANDARD SCREWS** IN THE **HIGHLIGHTED HOLES**. TIGHTEN THEM UP, MAKE SURE THEY SWING SMOOTHLY, AND THAT'S IT—YOUR FILAMENT COMPARTMENTS ARE OFFICIALLY OPERATIONAL! 🚀

WWW.CC3DPROJECTS.COM

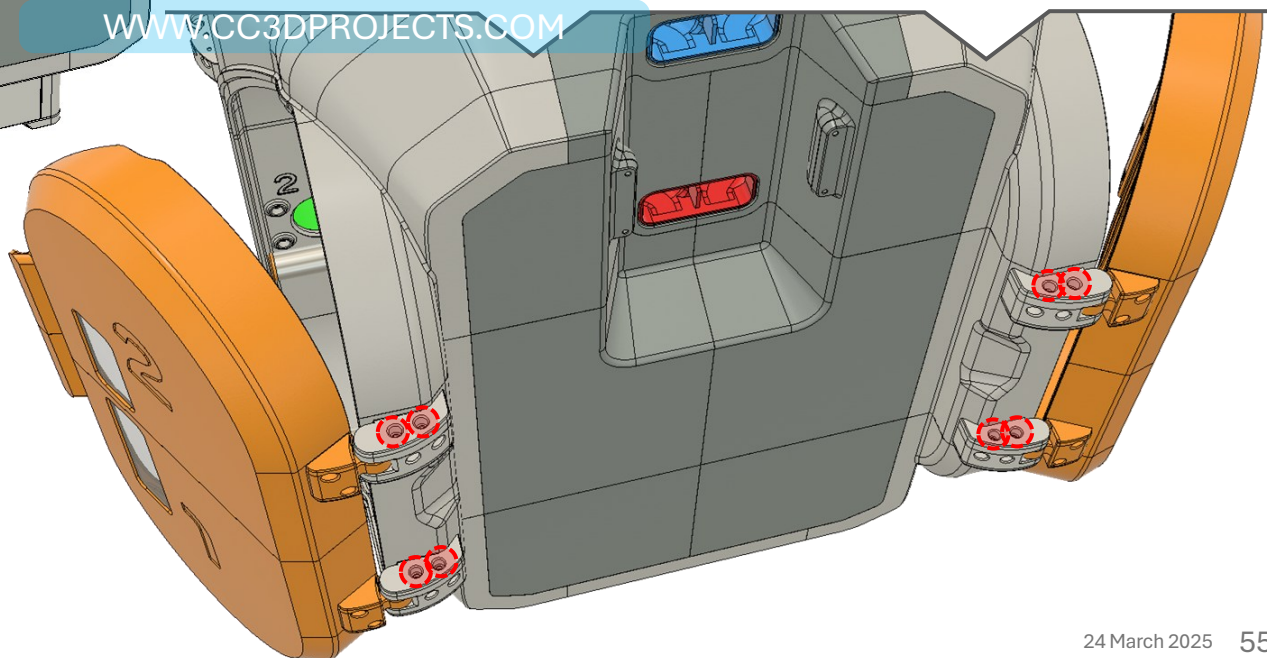



# FRONT DOOR INSTALLATION

Buy me a coffee



ALL MATERIAL PRODUCED AND PROVIDED HAS BEEN CONCEIVED, AUTHORED AND PRODUCED BY ENRICO MAZZAROL - ALL RIGHTS RESERVED.

## LET'S INSTALL THE FRONT DOORS!

NOW IT'S TIME TO MOUNT THE **MAIN FRONT DOORS** ONTO THE ENCLOSURE.

USE THE **MATCHING DOOR PIECES** THAT ALIGN WITH THE HINGES ALREADY INSTALLED ON THE FRAME. POSITION THEM CAREFULLY, THEN **SECURE EVERYTHING USING THE STANDARD SCREWS** IN THE HIGHLIGHTED HOLES.

ONCE TIGHTENED, GIVE THEM A TEST SWING—SMOOTH MOTION, PERFECT ALIGNMENT, AND BOOM—YOUR ENCLOSURE IS REALLY COMING TOGETHER! 🔥

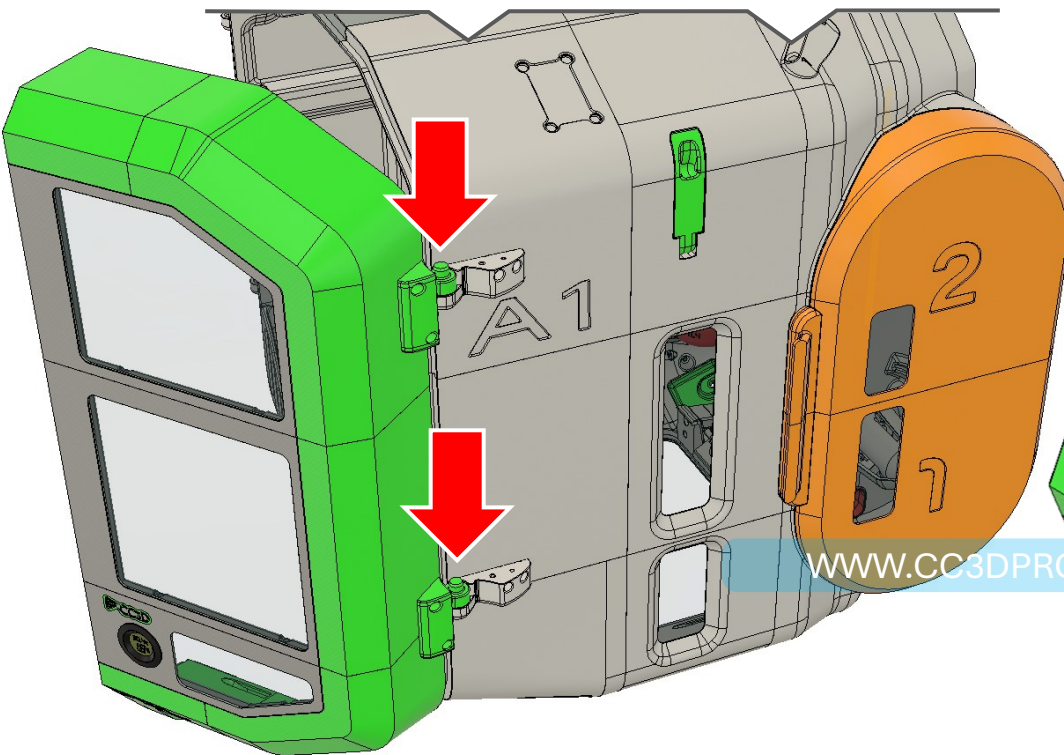

WWW.CC3DPROJECTS.COM

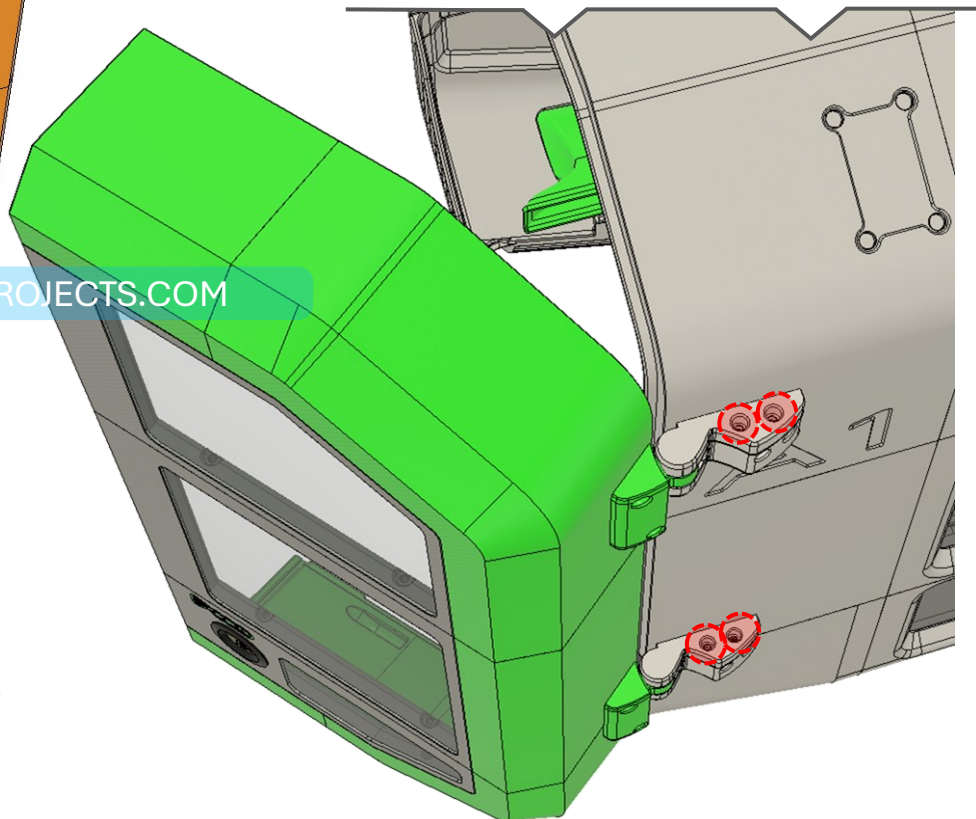

SAME PROCESS AS BEFORE—GRAB THE **LEFT DOOR** AND ALIGN IT WITH THE HINGES ALREADY MOUNTED ON THE FRAME.

MAKE SURE EVERYTHING LINES UP NICELY, THEN **SECURE IT USING THE STANDARD SCREWS** IN THE HIGHLIGHTED HOLES.

ONCE IT'S LOCKED IN PLACE, TEST THE SWING—SMOOTH, ALIGNED, AND LOOKING GREAT. ONE STEP CLOSER TO THE FINISH LINE! 🍌 🔥



### LET'S INSTALL THE NFC RINGS FOR FILAMENT DETECTION!

HOW DID I DO IT? SIMPLE—I **CUT THE CABLES AND EXTENDED THEM** SINCE FINDING THE RIGHT PLUGS ON THE MARKET WAS BASICALLY IMPOSSIBLE.

SO HERE'S WHAT YOU NEED TO DO:

- 1 **EXTEND THE CABLES** JUST LIKE I DID—THIS GIVES YOU THE REACH YOU NEED.
- 2 **GLUE THE NFC RINGS IN PLACE** USING **FAST-DRYING GLUE** TO SECURE THEM.
- 3 **FOR EXTRA HOLD**, FOLLOW UP WITH **PHONE REPAIR ADHESIVE** TO KEEP EVERYTHING NEAT AND STURDY, JUST LIKE SHOWN IN THE DIAGRAM. AND THAT'S IT—YOUR NFC SETUP IS GOOD TO GO! 🚀

### ONE MORE THING—CABLE MANAGEMENT DONE RIGHT!

OF COURSE, I DIDN'T JUST EXTEND THE CABLES RANDOMLY—I MADE SURE **ALL CABLES WERE EXTENDED TO THE SAME LENGTH** (ABOUT 60 CM) FOR A CLEAN AND UNIFORM SETUP.

ONCE THE **NFC RINGS WERE GLUED TO THE STRUCTURE**, I NEATLY **WRAPPED ALL THE CABLES TOGETHER** USING **CLOTH TAPE**. THIS KEEPS EVERYTHING ORGANIZED, PREVENTS TANGLES, AND MAKES YOUR BUILD LOOK SUPER PROFESSIONAL. 🍌🔥

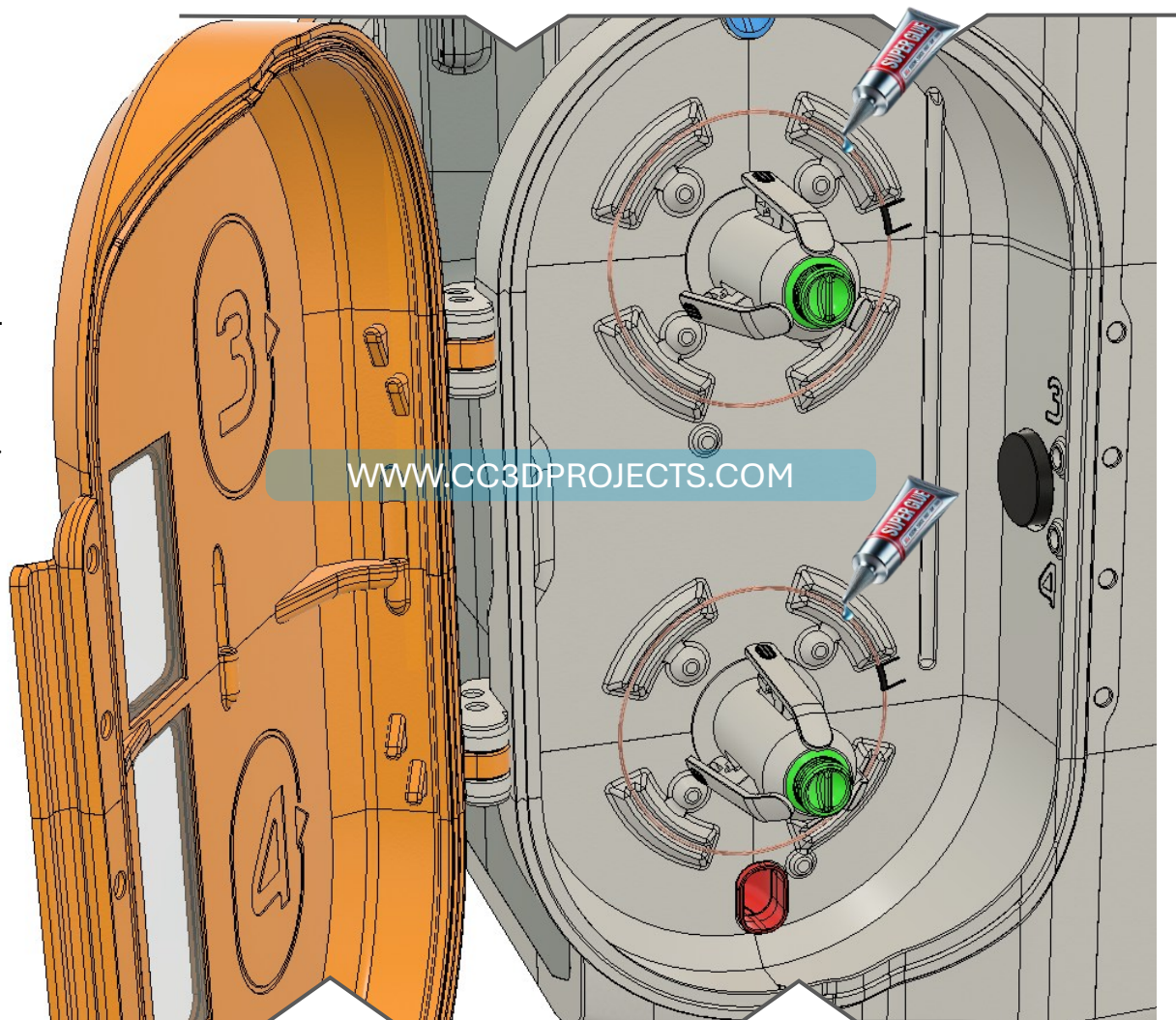

[WWW.CC3DPROJECTS.COM](http://WWW.CC3DPROJECTS.COM)

Buy me a coffee





## ROUTING THE CABLES LIKE A PRO!

NOW IT'S TIME TO **ROUTE THE CABLES** EXACTLY AS SHOWN IN THE DIAGRAM, MAKING SURE THEY REACH THE **HOLES ON THE TOP**—THAT'S WHERE THEY'LL CONNECT TO THE AMS ELECTRONICS BOARD.

**🔧 REPEAT THIS PROCESS ON BOTH SIDES**, KEEPING THE CABLES NEAT AND FOLLOWING THE SAME PATH.

TAKE YOUR TIME—CLEAN CABLE MANAGEMENT NOW MEANS FEWER HEADACHES LATER! 💡💪

Buy me a coffee

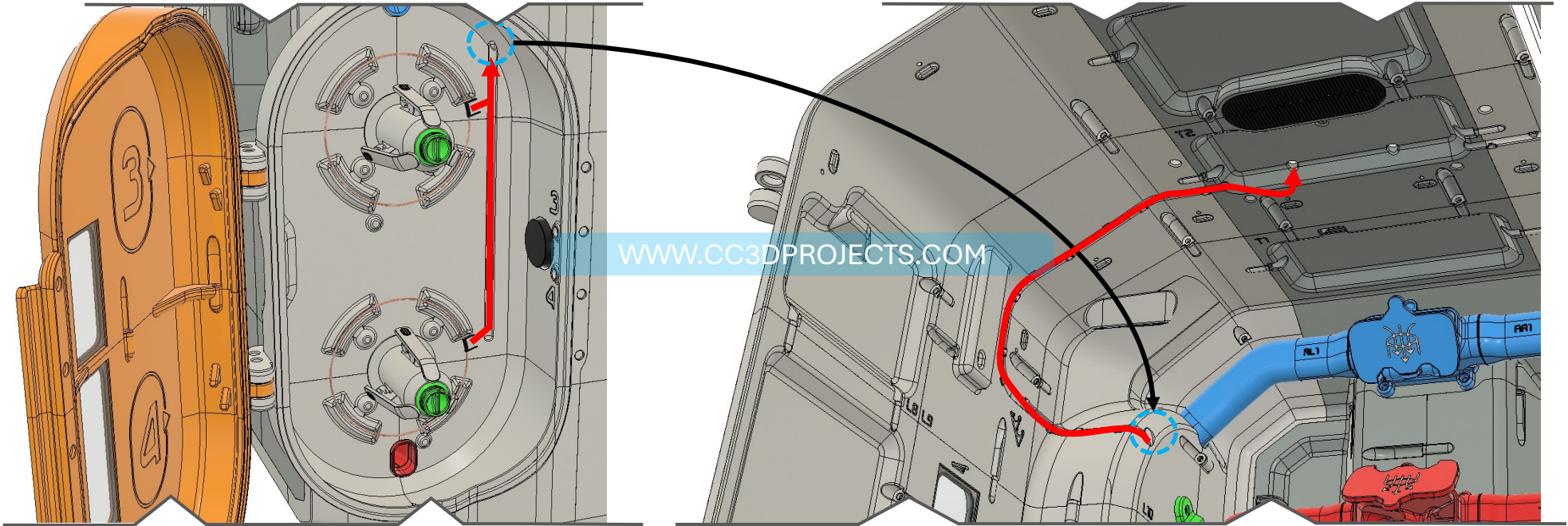



# AMS NFC READER INSTALLATION

# ENCLOSURE A1



## FINAL STEP: CONNECT THE PLUGS!

NOW, JUST FOLLOW THE **WIRING DIAGRAM** AND CONNECT THE PLUGS EXACTLY AS SHOWN. DOUBLE-CHECK EACH CONNECTION—GET IT RIGHT, AND YOU'RE ALL SET!   
ONCE EVERYTHING IS PLUGGED IN, YOU'RE OFFICIALLY **GOOD TO GO!** 🚀

Buy me a coffee

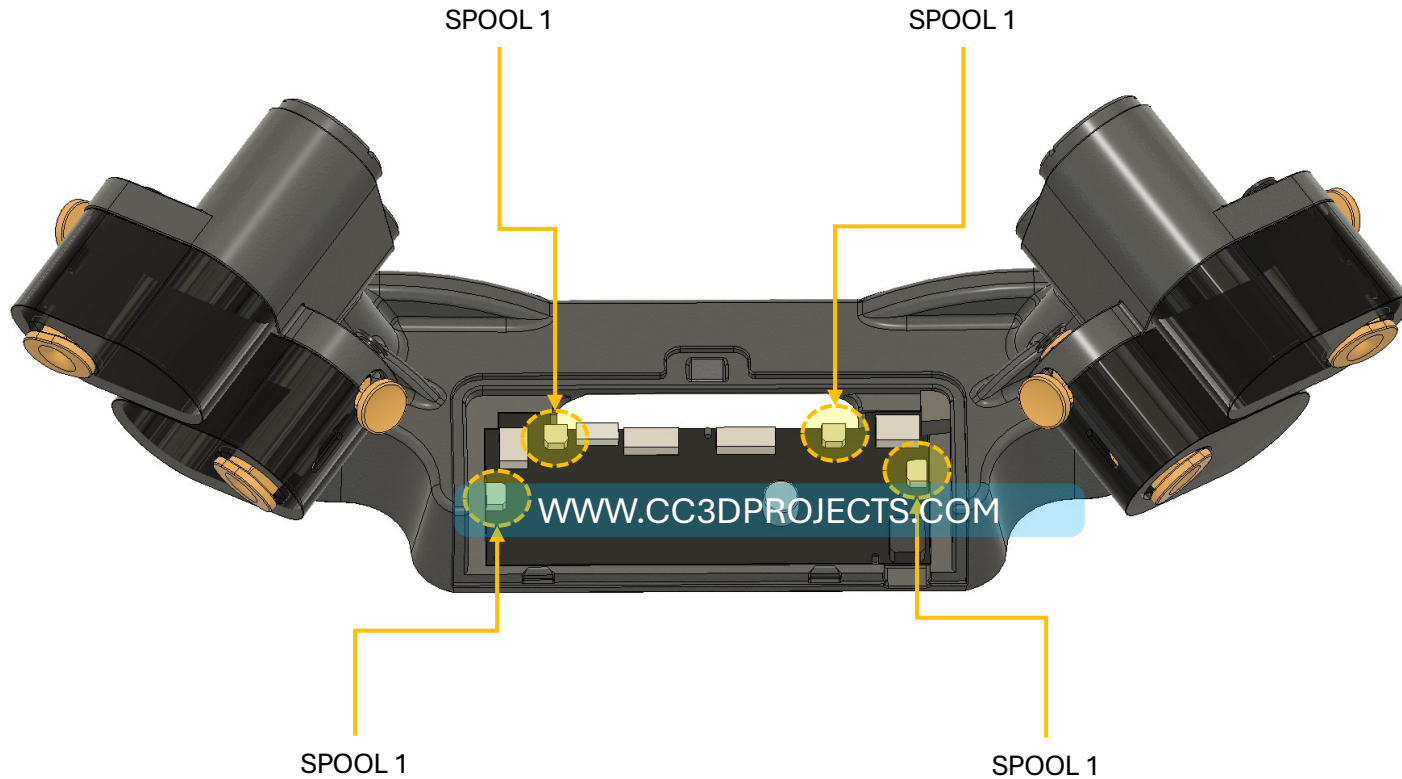

ALL MATERIAL PRODUCED AND PROVIDED HAS BEEN CONCEIVED, AUTHORED AND PRODUCED BY ENRICO MAZZAROL - ALL RIGHTS RESERVED.



# PTFE TUBE INSTALLATION



LET'S INSTALL THE FILAMENT GUIDE TUBES!

- 1 CUT FOUR PTFE TUBES, EACH 59 CM LONG—PRECISION MATTERS HERE! ✂️
- 2 FOLLOW THE IMAGES TO INSTALL THE TUBES CORRECTLY IN THEIR DESIGNATED PATHS.
- 3 ONCE IN PLACE, SECURE THEM USING THE STOPPERS—YOU SHOULD HAVE PRINTED THESE EARLIER, AND THEY'RE READY TO GO! MAKE SURE EVERYTHING IS SNUG AND ALIGNED—SMOOTH FILAMENT FLOW IS KEY! 🔥🔧

Buy me a coffee

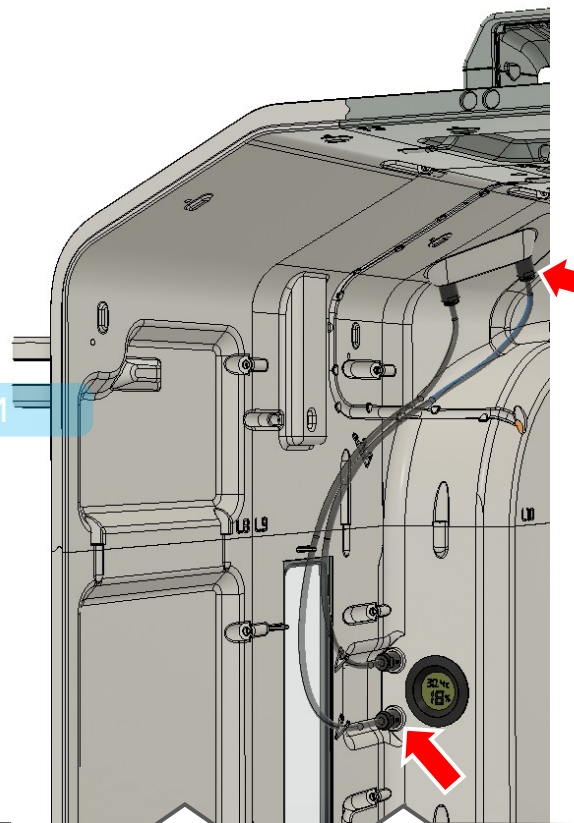
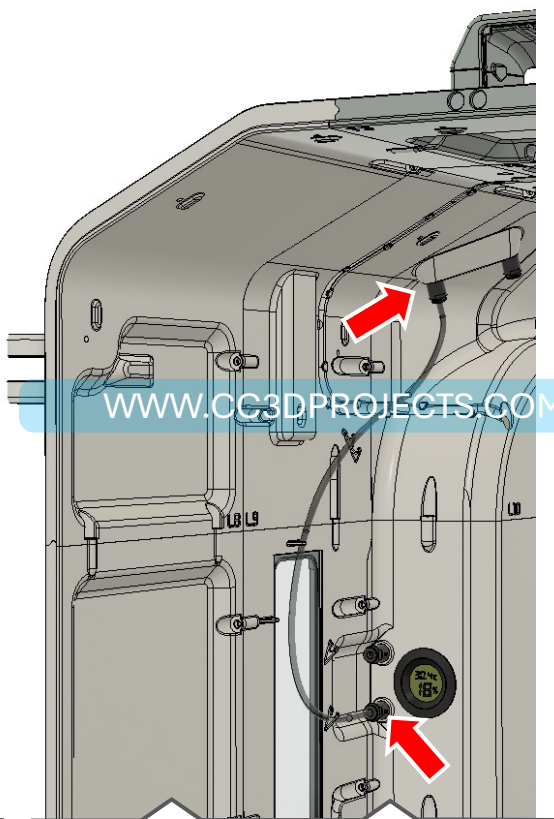
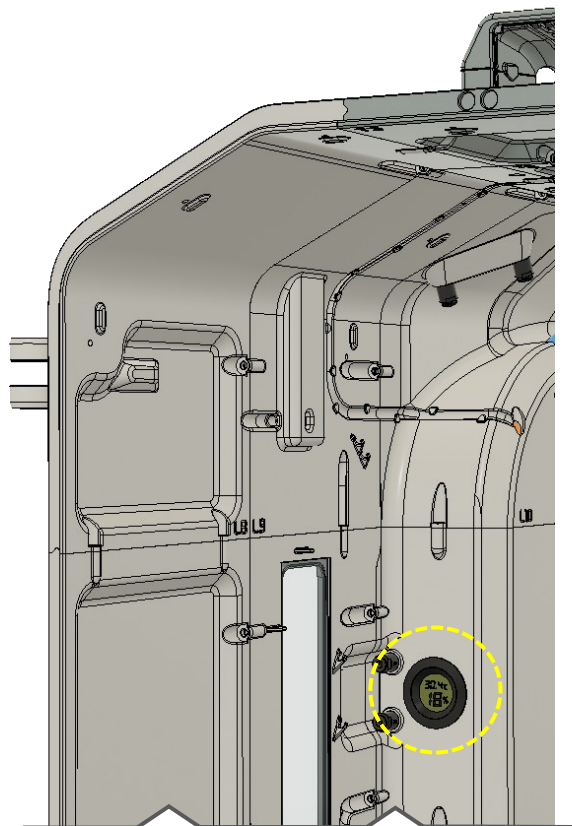



# SPOOL HOLDERS

# ENCLOSURE A1



**THIS STEP IS CRUCIAL—DON'T SKIP IT!** ⚠️

IF YOU USE THE FILAMENT HOLDERS AS THEY COME, YOU'LL LIKELY RUN INTO A PROBLEM DURING YOUR PRINTS. THE **SPRINGS ARE TOO STIFF**, MAKING IT HARD FOR THE PRINTER TO PULL THE FILAMENT—WHICH CAN LEAD TO JAMS OR FAILED PRINTS.

SO HERE'S WHAT WE'RE GOING TO DO:

WE'LL **REMOVE THE SPRINGS AND THE REAR PLATE** THAT ENGAGES THEM. WHILE WE'RE AT IT, WE'LL ALSO **UPGRADE THE HOLDERS** TO FIT **ANY KIND OF SPOOL** MORE COMFORTABLY.

TO DISASSEMBLE THE STOCK HOLDERS, USE THE EXCELLENT GUIDE BY **@BIGJON1378**—HUGE THANKS TO HIM FOR THE HELP! 🙌

ONCE EVERYTHING IS TAKEN APART, JUST **SWAP IN THE PRINTED PARTS** AS SHOWN IN THE IMAGES.

THEN YOU'LL BE READY TO INSTALL THE NEW, IMPROVED SPOOL ROTORS DIRECTLY INTO THE ENCLOSURE!

BETTER FLOW, SMOOTHER PRINTING. LET'S DO THIS! 🙌🔗

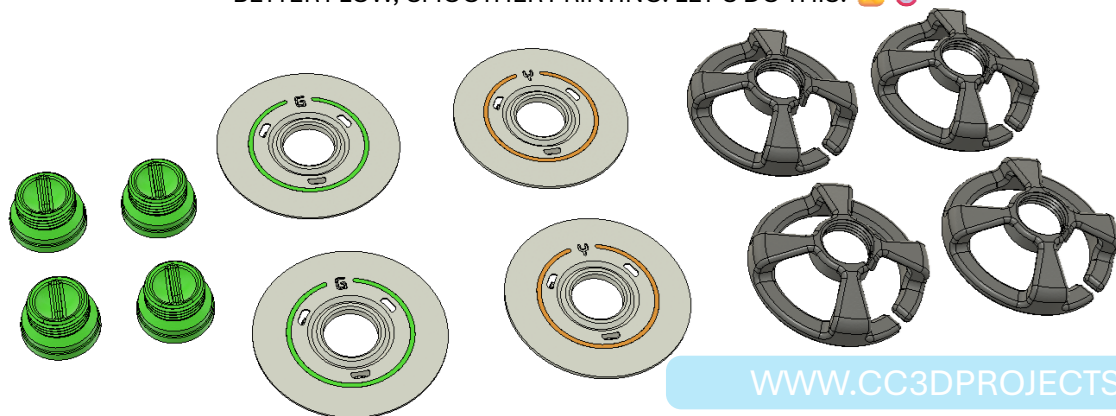

[WWW.CC3DPROJECTS.COM](http://WWW.CC3DPROJECTS.COM)



SCAN ME

SPECIAL THANKS TO **@BIGJON1378!** 🙌

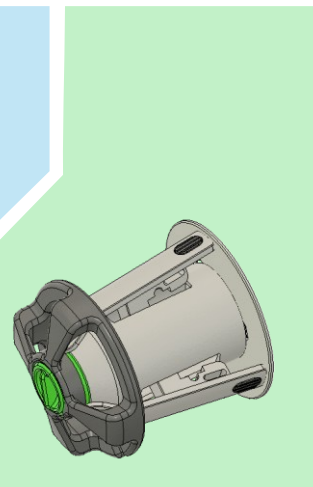
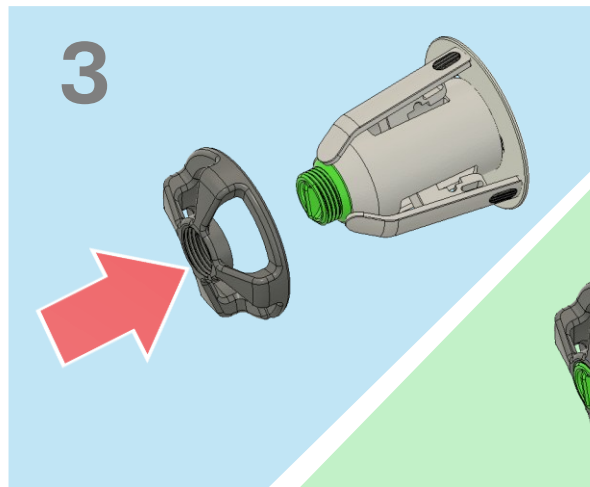
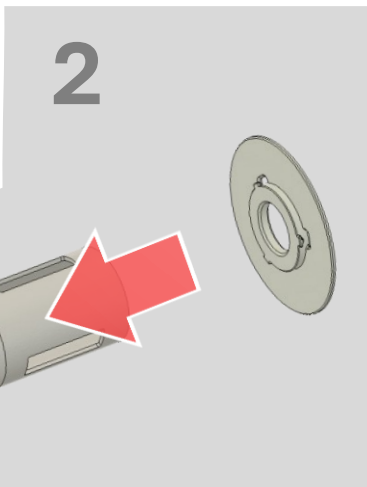
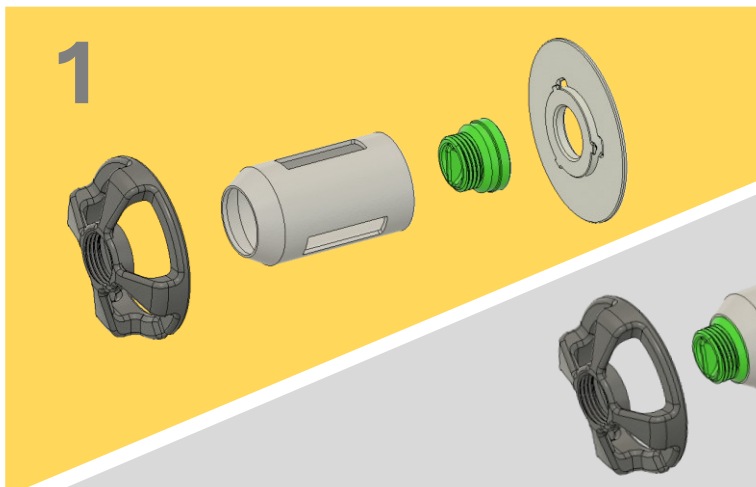

Buy me a coffee



# PRINTER PLACEMENT



EASY DOES IT—LET'S PLACE THE PRINTER INSIDE THE ENCLOSURE! 🖨️🔧 NOW TAKE YOUR TIME—GENTLY SLIDE THE PRINTER INTO THE ENCLOSURE UNTIL IT'S PERFECTLY SEATED ON THE DRAWER.GO SLOW, MAKE SURE EVERYTHING LINES UP, AND LET IT REST SNUGLY IN POSITION.NO FORCING, NO TILTING—JUST A SMOOTH LANDING.AND JUST LIKE THAT, YOUR PRINTER IS OFFICIALLY HOME! 🏠🔥

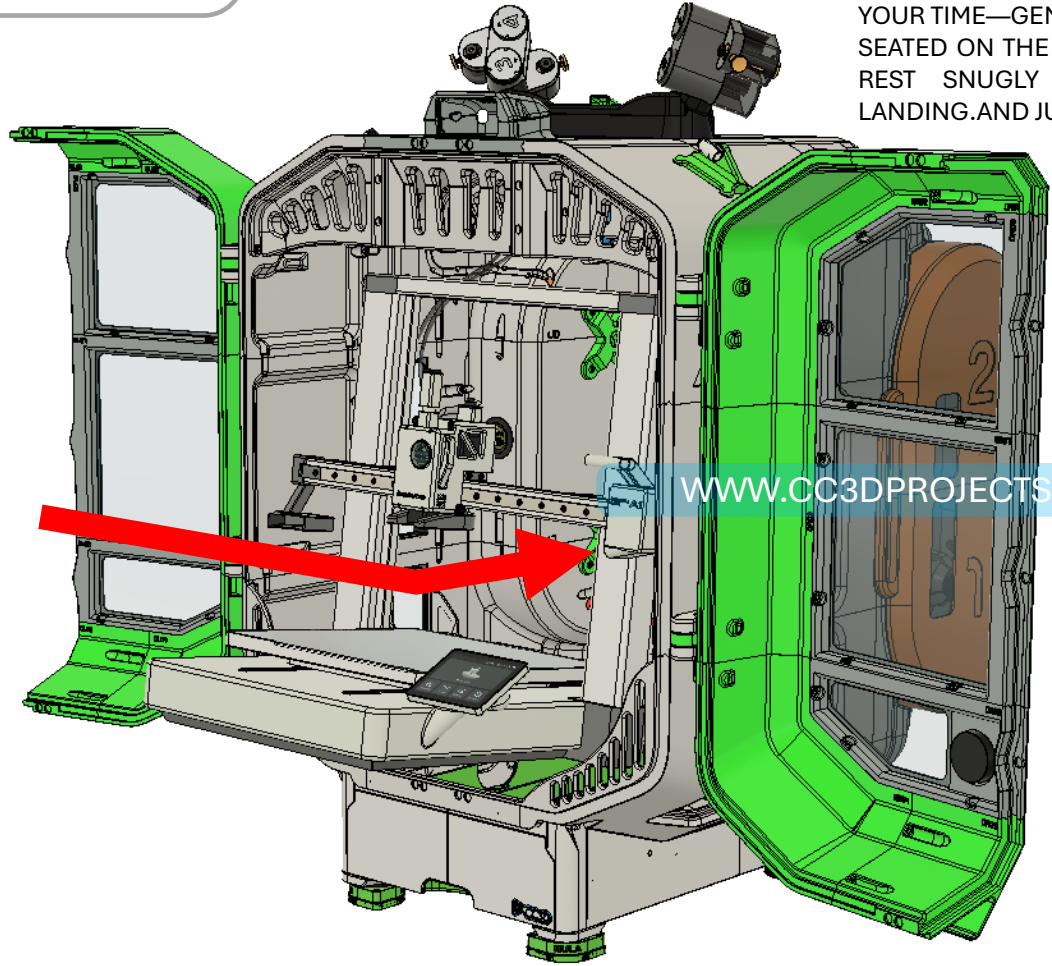

[WWW.CC3DPROJECTS.COM](http://WWW.CC3DPROJECTS.COM)

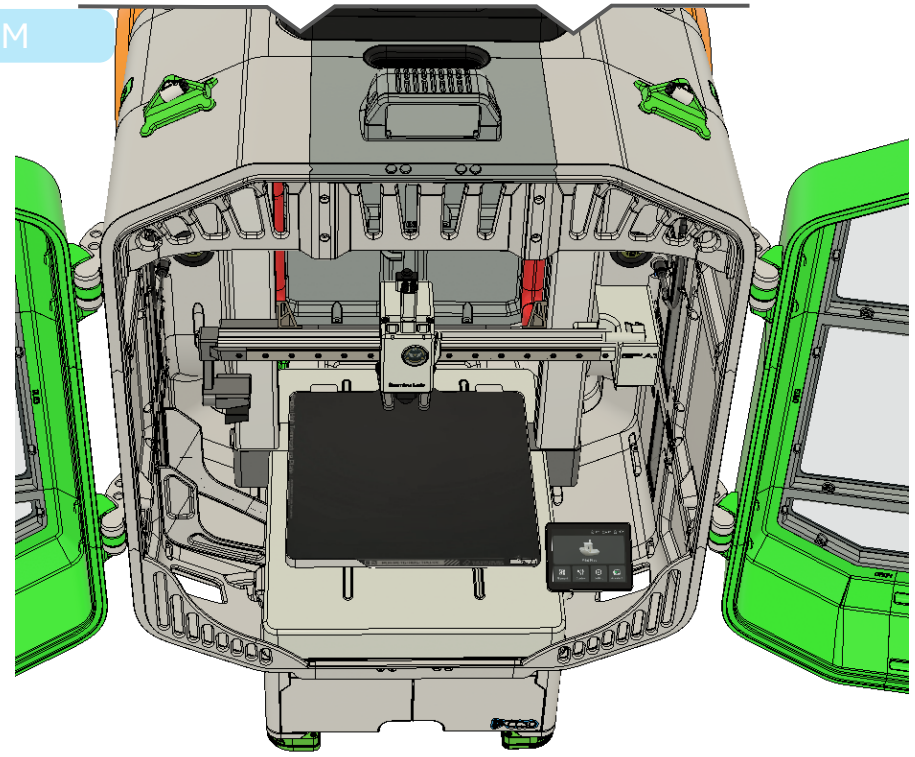

ALL MATERIAL PRODUCED AND PROVIDED HAS BEEN CONCEIVED, AUTHORED AND PRODUCED BY ENRICO MAZZAROL - ALL RIGHTS RESERVED.



**EASY DOES IT—LET'S PLACE THE PRINTER INSIDE THE ENCLOSURE!** 🖨️ ✨

NOW TAKE YOUR TIME—**GENTLY SLIDE THE PRINTER INTO THE ENCLOSURE** UNTIL IT'S PERFECTLY SEATED ON THE DRAWER. GO SLOW, MAKE SURE EVERYTHING LINES UP, AND LET IT REST SNUGLY IN POSITION.

NO FORCING, NO TILTING—JUST A SMOOTH LANDING. AND JUST LIKE THAT, YOUR PRINTER IS OFFICIALLY HOME! 🏠 🔥

Buy me a coffee

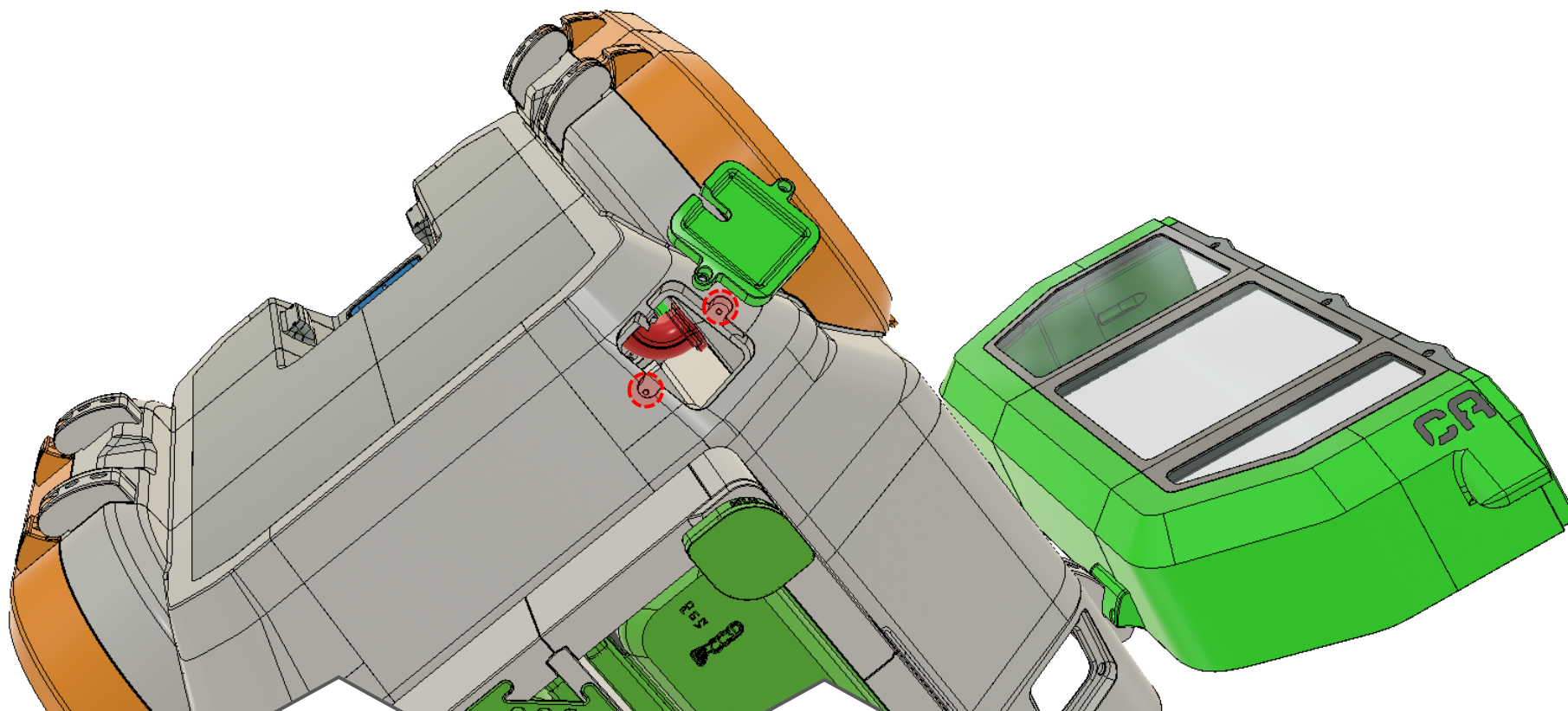



# PRINTER CABLE MANAGEMENT

# ENCLOSURE A1



**TIME TO CONNECT THE AMS TO THE PRINTER!**

- 1 START BY **PLUGGING THE AMS CABLE INTO THE BOARD** LOCATED ON TOP OF THE ENCLOSURE.
- 2 NEXT, **REMOVE THE TOP GASKET** AND CAREFULLY THREAD THE CABLE THROUGH THE OPENING.
- 3 GRAB THE **CLIP SHOWN BELOW**, WHICH SHOULD ALREADY HAVE A **MAGNET GLUED ON USING APPLICATOR B**—NICE!

4 **REINSTALL THE GASKET**, ROUTE THE CABLE **BEHIND THE RED PIPE**, AND THEN **CONNECT IT TO THE PRINTER**.

5 **FINALLY, SNAP THE CLIP ONTO THE MAGNET** ON THE BACK WALL—AND VOILÀ, THE CABLE IS CLEANLY SECURED AND PERFECTLY IN PLACE!

SLICK, ORGANIZED, AND READY TO ROLL! 🎯🔥

FAMMI SAPERE SE VUOI AGGIUNGERE UN PICCOLO SCHEMA DEL PERCORSO DEL CAVO O PASSIAMO AL PROSSIMO STEP!

Buy me a coffee

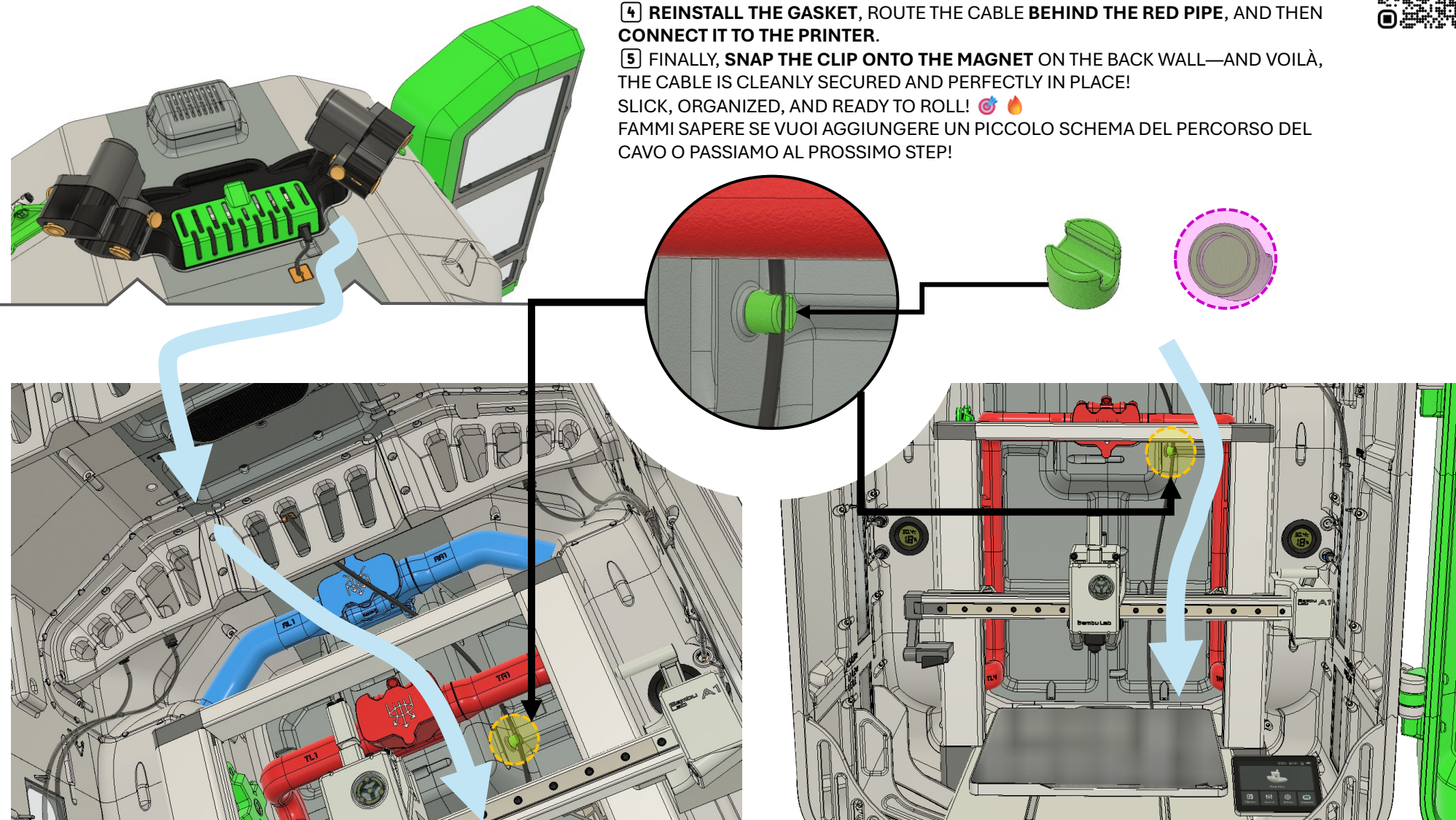

ALL MATERIAL PRODUCED AND PROVIDED HAS BEEN CONCEIVED, AUTHORED AND PRODUCED BY ENRICO MAZZAROL - ALL RIGHTS RESERVED.

## VENT DUCTS



## ENCLOSURE A1



LET'S TALK ABOUT THE VENT DUCTS FOR COOLING THE PRINTER'S MAINBOARD! 🌀

YOU'VE GOT TWO OPTIONS HERE:

- 1 A STATIC VERSION, WHICH INCLUDES SIMPLE VENT GRILLS.
- 2 A FAN-READY VERSION, DESIGNED FOR 40 X 40 MM FANS, EASILY IDENTIFIED BY THE 4 MOUNTING HOLES.

IF YOU GO WITH THE FAN OPTION, KEEP IN MIND: IT'S ENTIRELY UP TO YOU! THERE ARE TONS OF SOLUTIONS OUT THERE, SO I WON'T GO INTO DETAIL. YOU GET TO DECIDE HOW YOU WANT TO SET IT UP. 🙌

WHAT I WILL SHOW YOU IS HOW TO INSTALL THE DUCTS THEMSELVES: 🖐️ GRAB THE DUCTS YOU'VE CHOSEN, AND GLUE 8 MAGNETS INTO PLACE USING APPLICATOR **B**—MAKE SURE THEY'RE SEATED FIRMLY AND ALIGNED PROPERLY. AND THAT'S IT—READY FOR AIRFLOW, YOUR WAY! 🧠👓 FAMMI SAPERE SE VUOI AGGIUNGERE UNA MINI GUIDA PER ALIMENTARE LE VENTOLE O ANDIAMO AVANTI!

Buy me a coffee

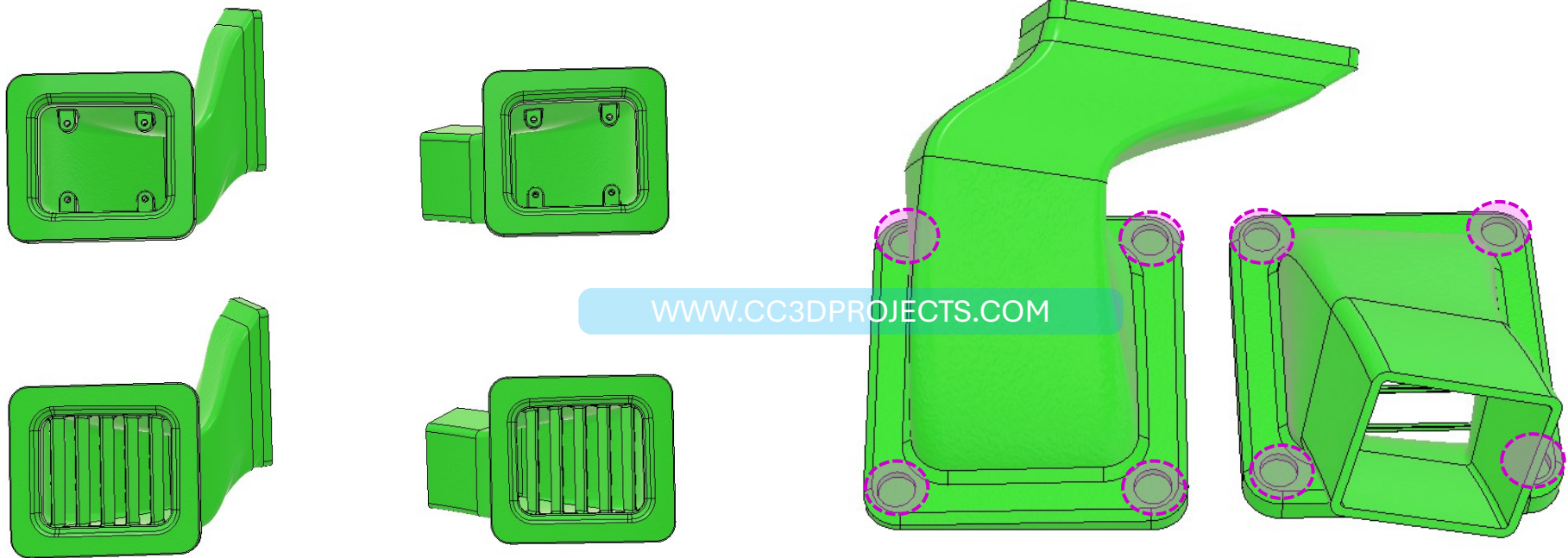



# VENT DUCT

## INSTALLING THE DUCTS—A LITTLE TRICKIER ON THE LEFT! 🌱🍷

HEADS UP: THE **LEFT DUCT** MIGHT BE A LITTLE TRICKIER TO INSTALL DUE TO ITS POSITION AND SHAPE—BUT DON'T WORRY, I'VE GOT YOU COVERED.

I'VE INCLUDED A **SHORT VIDEO** TO SHOW YOU EXACTLY HOW TO SLIDE IT INTO PLACE WITHOUT ANY STRESS.

THE **RIGHT DUCT**, ON THE OTHER HAND, IS A BREEZE—SUPER SIMPLE TO POSITION AND SNAP IN.

TAKE YOUR TIME, FOLLOW THE VISUAL, AND YOU'LL HAVE BOTH DUCTS INSTALLED LIKE A PRO IN NO TIME! 🎥✅

LET ME KNOW IF YOU WANT A STEP-BY-STEP BREAKDOWN OF THE VIDEO TOO!

Buy me a coffee



INSERISCI IL VIDEO PER INSTALLARE LA DUCK DI SINISTRA

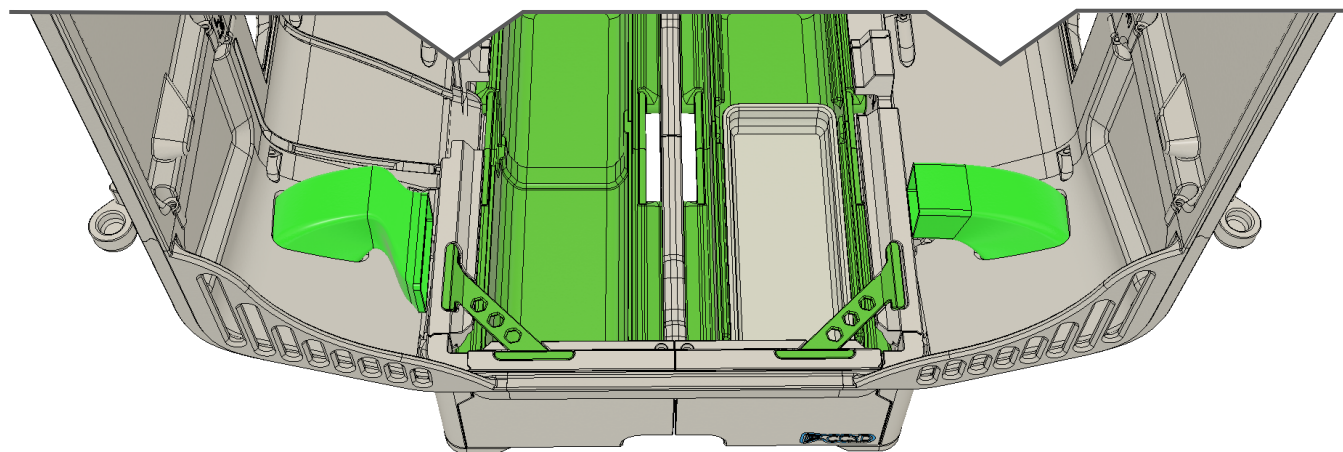
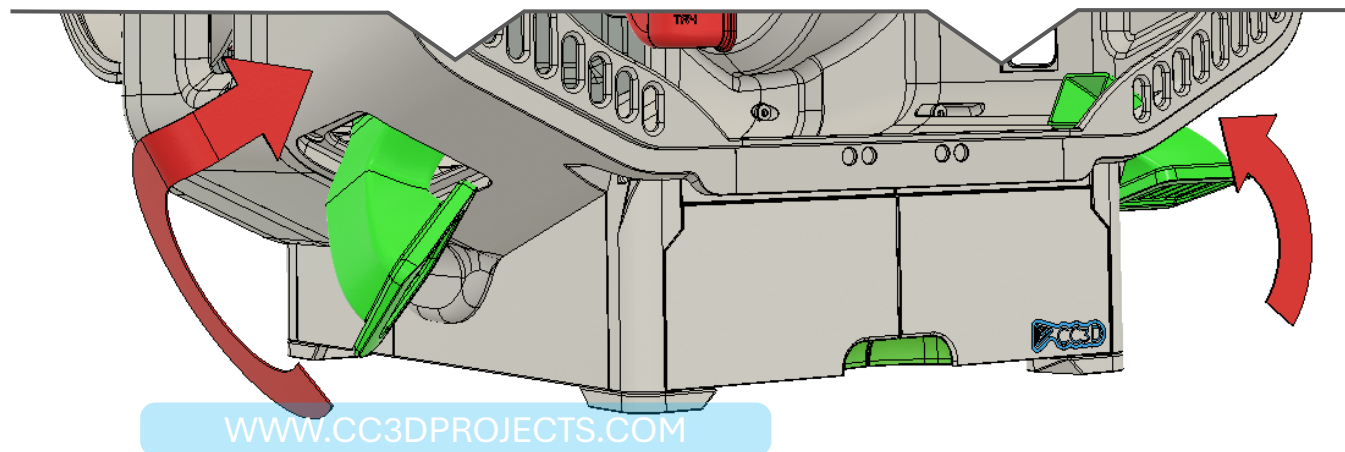



# POLYDRYER INSTALLATION

# ENCLOSURE A1



## LET'S TALK DRYER SETUP! 🔥🧠

YOU'VE GOT **TWO INSTALLATION OPTIONS** FOR YOUR POLYDRYER:

1 THE FIRST—AND THE ONE WE'LL COVER OVER THE **NEXT TWO PAGES**—IS TO INSTALL THE **POLYDRYER AS-IS**, STRAIGHT OUT OF THE BOX. SIMPLE AND EFFECTIVE!

2 THE SECOND OPTION IS A BIT MORE ADVANCED: IT INVOLVES **RELOCATING THE CONTROL PANEL** TO THE **FRONT OF THE ENCLOSURE** FOR EASIER ACCESS AND A SLEEKER LOOK.

WE'LL WALK THROUGH THE STANDARD INSTALL FIRST—THEN YOU CAN DECIDE IF YOU WANT TO GO THE EXTRA MILE. LET'S GET TO IT! 🚀

Buy me a coffee

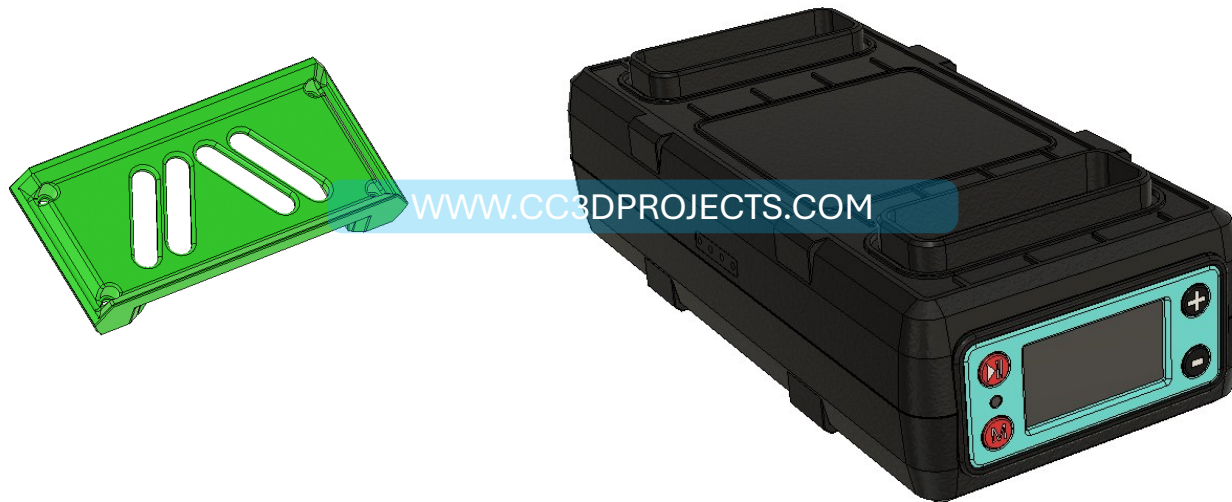

ALL MATERIAL PRODUCED AND PROVIDED HAS BEEN CONCEIVED, AUTHORED AND PRODUCED BY ENRICO MAZZAROL - ALL RIGHTS RESERVED.



Buy me a coffee



## STANDARD DRYER INSTALLATION—NICE AND EASY!



THIS ONE'S A BREEZE:

- 1 GRAB YOUR **POLYDRYER** AND POSITION IT WITH THE **DISPLAY FACING UP**.
- 2 SLIDE IT INTO THE DESIGNATED SLOTS/HOLES—EVERYTHING SHOULD ALIGN SMOOTHLY.
- 3 ONCE IT'S IN PLACE, USE THE **DRYER SUPPORT BRACKET** AND **SECURE IT WITH THE FOUR REQUIRED SCREWS**.
- 4 THAT'S IT—**YOU'RE DONE!** DRYER INSTALLED, NO SWEAT!

READY FOR DRY, TANGLE-FREE FILAMENT—LET'S KEEP PRINTING LIKE A CHAMP! 🏆🔥

FAMMI SAPERE SE VUOI UN PICCOLO REMINDER PER IL ROUTING DEI TUBI DAL DRYER!

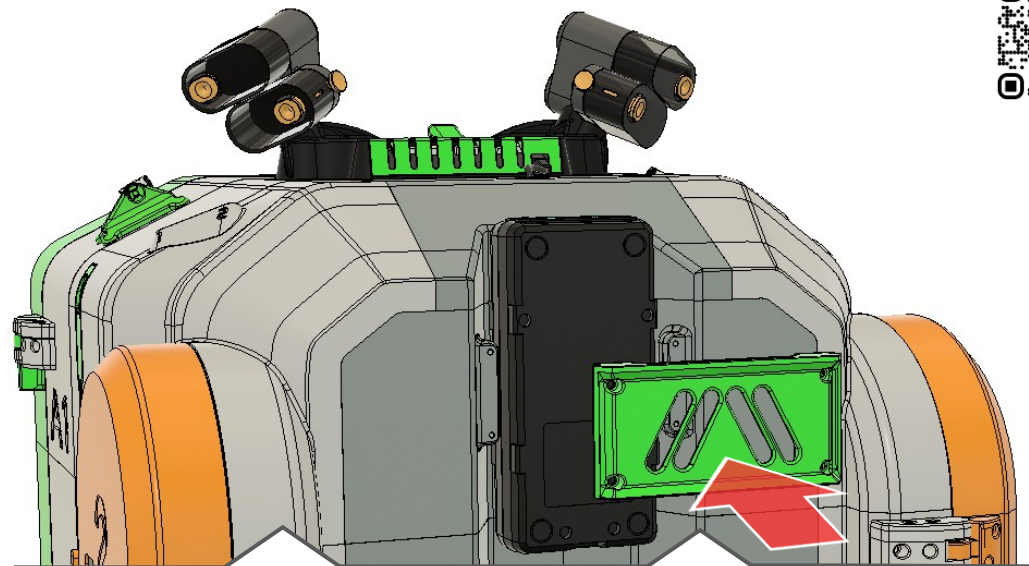

WWW.CC3DPROJECTS.COM

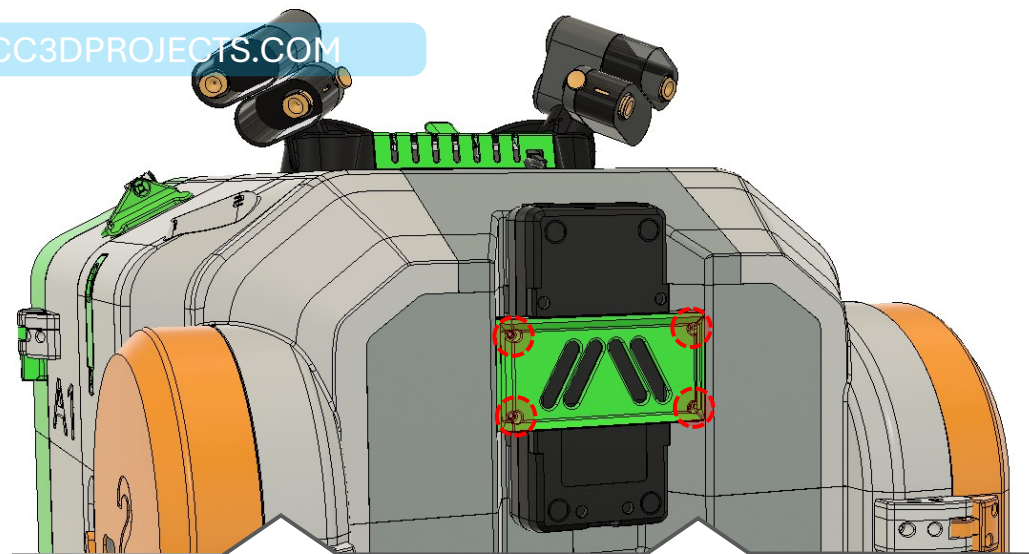



## DISCLAIMER – PRODUCT MODIFICATIONS AND LIABILITY WAIVER

BEFORE PROCEEDING WITH THE ASSEMBLY AND SELECTION OF COMPONENTS, IT IS IMPORTANT TO REVIEW THE FOLLOWING INFORMATION AND ACCEPT THE TERMS REGARDING POTENTIAL PRODUCT MODIFICATIONS.

INSTALLING THE POLYDRYER CONTROL PANEL ON THE MODULE DOOR REQUIRES SUBSTANTIAL MODIFICATIONS TO THE ELECTRICAL AND ELECTRONIC CONNECTIONS OF THE DEVICE, WHICH MAY PRESENT SIGNIFICANT RISKS. ONE OF THE NECESSARY CHANGES INVOLVES EXTENDING THE CABLES BY APPROXIMATELY 60 CM.

WHILE USING STANDARD CONNECTORS MAY ALLOW THE MODIFICATION TO REMAIN REVERSIBLE, IT IS CRUCIAL TO HAVE THE APPROPRIATE TECHNICAL KNOWLEDGE IN ELECTRICAL AND ELECTRONIC SYSTEMS TO PERFORM THIS OPERATION SAFELY. IF YOU LACK SUCH EXPERTISE, YOU MUST SEEK ASSISTANCE FROM A CERTIFIED TECHNICIAN OR PROFESSIONAL.

### RISK WARNING:

IMPROPER OR NON-COMPLIANT MODIFICATIONS MAY RESULT IN:

- PRODUCT MALFUNCTIONS,
- SHORT CIRCUITS,
- SPARKS OR FIRE,
- PERSONAL INJURY,
- PROPERTY DAMAGE

PLEASE NOTE THAT I DO NOT ENCOURAGE OR AUTHORIZE UNSAFE OR UNCERTIFIED MODIFICATIONS. I URGE YOU TO FOLLOW ALL SAFETY GUIDELINES DURING TECHNICAL OPERATIONS.

### LIABILITY

BY PROCEEDING WITH THESE MODIFICATIONS, YOU ACCEPT FULL LEGAL AND FINANCIAL RESPONSIBILITY FOR ANY CONSEQUENCES, INCIDENTS, OR DAMAGES TO PEOPLE, ANIMALS, OR PROPERTY THAT MAY RESULT FROM YOUR ACTIONS.

I EXPRESSLY DISCLAIM ANY LIABILITY FOR:

- DIRECT, INDIRECT, OR CONSEQUENTIAL DAMAGES,
- MALFUNCTIONS OR FAILURES OF THE MODIFIED PRODUCT,
- VIOLATIONS OF SAFETY REGULATIONS OR PRODUCT CERTIFICATIONS,
- ACCIDENTS CAUSED BY NEGLIGENCE, RECKLESSNESS, OR LACK OF EXPERTISE DURING THE MODIFICATION PROCESS.

### LEGAL

PLEASE BE AWARE THAT MODIFYING THE PRODUCT MAY VOID ANY WARRANTY AND/OR INVALIDATE PRODUCT CERTIFICATIONS (E.G., CE MARKING, UL CERTIFICATIONS), RENDERING THE PRODUCT NON-COMPLIANT WITH APPLICABLE SAFETY AND QUALITY STANDARDS.

BY PROCEEDING WITH THE MODIFICATIONS, YOU CONFIRM THAT YOU HAVE READ, UNDERSTOOD, AND ACCEPTED THIS DISCLAIMER IN ITS ENTIRETY.

### LIMITATION:

### NOTICE:

All material produced and provided has been conceived, authored and produced by Enrico Mazzaroli - All rights reserved.



# POLYDRYER INSTALLATION

# ENCLOSURE A1



## INSTALLING THE POLYDRYER SPECIAL EDITION! 🔧🔥

THIS SETUP REQUIRES A BIT MORE WORK, BUT DON'T WORRY—IT'S ALL **PLUG & PLAY** WITH THE RIGHT CONNECTORS. NO SOLDERING NEEDED!

### WHAT YOU'LL NEED:

- ✓ **DISASSEMBLE THE POLYDRYER**—WE NEED ACCESS TO THE INTERNAL WIRING.
- ✓ **USE SPECIFIC CONNECTORS** TO EXTEND THE CABLES WITHOUT CUTTING THEM:
  - JST-PH 2.0MM
  - JST-VH 3.96MM
  - JST-XH 2.5MM
- ✓ **A CRIMPING TOOL**—YOU WON'T NEED A SOLDERING IRON.
- ✓ **CLOTH TAPE** TO WRAP AND TIDY UP THE FINAL CABLE BUNDLE.
- ✓ **EXTEND THE CABLES BY APPROXIMATELY 45CM** ON AVERAGE.

ONCE EVERYTHING IS EXTENDED AND SECURED, YOU'RE READY FOR THE NEXT STEP! 🚀

LET ME KNOW IF YOU WANT A VISUAL GUIDE FOR CRIMPING THE CONNECTORS!

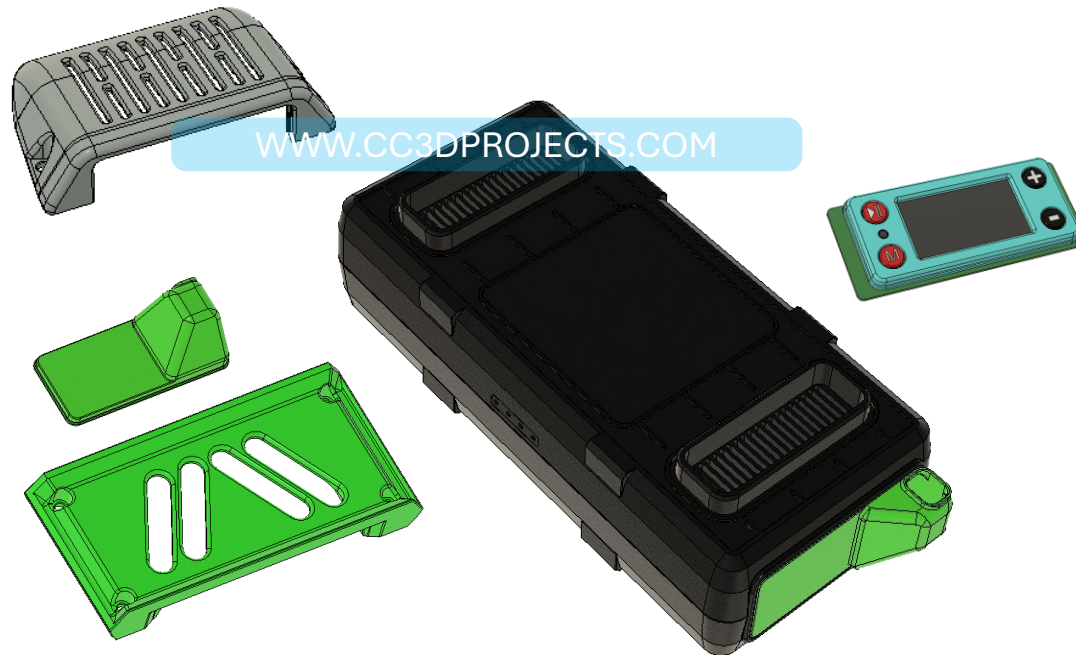

[WWW.CC3DPROJECTS.COM](http://WWW.CC3DPROJECTS.COM)

Buy me a coffee



ALL MATERIAL PRODUCED AND PROVIDED HAS BEEN CONCEIVED, AUTHORED AND PRODUCED BY ENRICO MAZZAROL - ALL RIGHTS RESERVED.



# POLYDRYER INSTALLATION

# ENCLOSURE A1



INSTALLING THE POLYDRYER SPECIAL—FINAL STEPS! 🔧 🔥 JUST LIKE BEFORE, LET’S GET EVERYTHING IN PLACE:

- 1 MOUNT THE DRYER ON THE BACK OF THE ENCLOSURE USING THE FOUR SCREWS—MAKE SURE IT’S FIRMLY SECURED.
- 2 MOVE TO THE FRONT SIDE AND INSTALL THE DRYER’S CONTROL PANEL IN ITS DESIGNATED SLOT.
- 3 LOCK IT IN PLACE BY ATTACHING THE COVER AND SECURING IT WITH THE TWO SCREWS.
- 4 THAT’S IT! EVERYTHING IS SET UP AND SECURED—JOB DONE! ✅ NOW YOUR POLYDRYER IS FULLY INTEGRATED AND READY TO KEEP YOUR FILAMENT IN PERFECT CONDITION! 🌀 🔥 LET ME KNOW IF YOU WANT A FINAL CHECKLIST BEFORE POWERING EVERYTHING UP! 🚀

Buy me a coffee

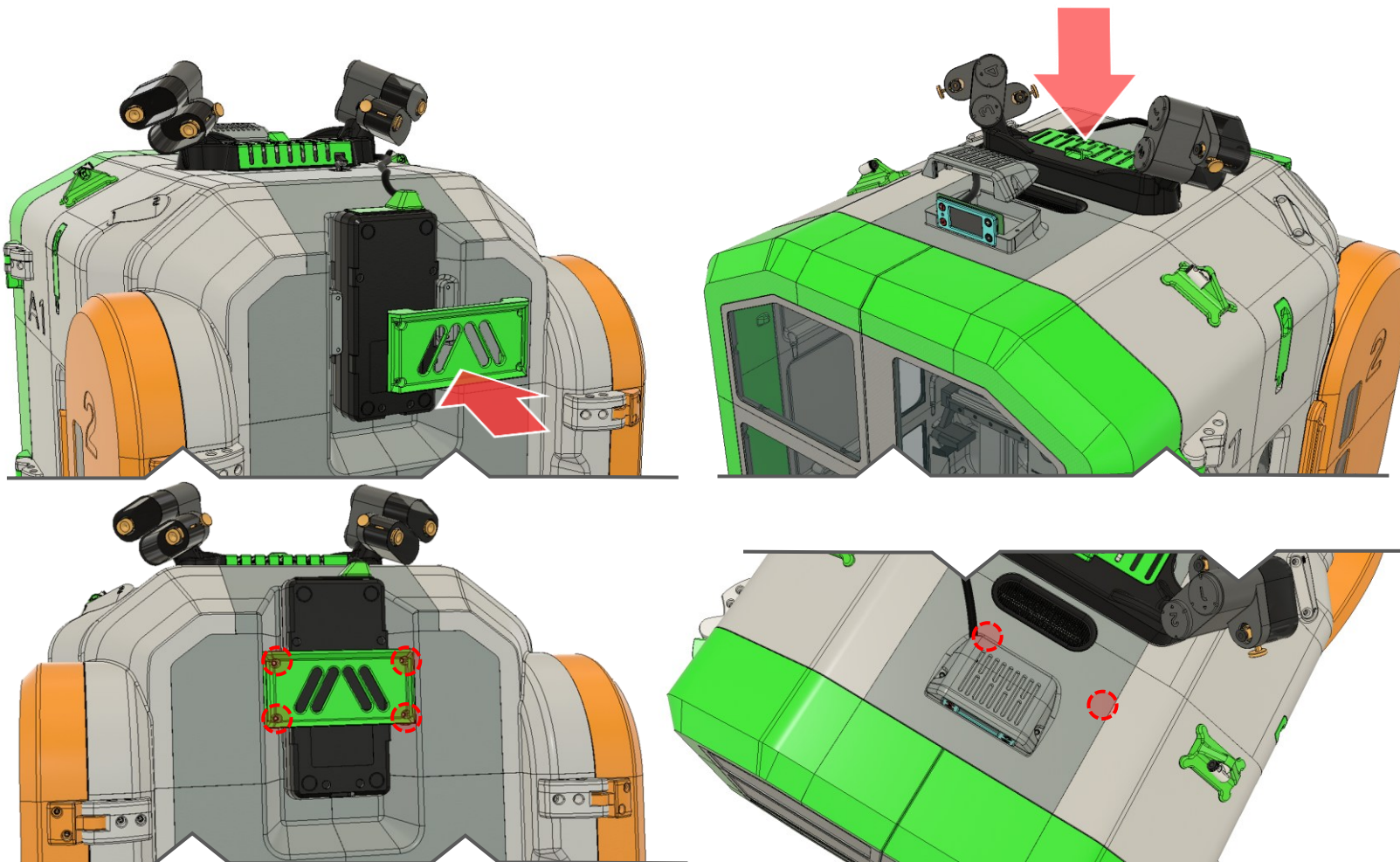



# EXTREMERAL SPOOL PTFE TUBE SUPPORT

# ENCLOSURE A1



Buy me a coffee



## FINAL STEP—(I THINK? 🤔) INSTALLING THE EXTERNAL SPOOL HOLDER TUBE SUPPORT! 🎨 🛠️

WE'RE ALMOST THERE! NOW LET'S PREP AND INSTALL THE **TUBE SUPPORT FOR AN EXTERNAL FILAMENT SPOOL.**

👉 **QUICK NOTE:** I'M INSTALLING **TWO** SUPPORTS, BUT IF YOU ONLY USE **ONE EXTERNAL SPOOL AT A TIME**, YOU CAN INSTALL **JUST ONE** INSTEAD.

### WHAT YOU NEED:

- ✓ **PRINTED TUBE SUPPORTS** (ONE OR TWO, DEPENDING ON YOUR SETUP).
- ✓ **BAMBU PTFE TUBE CONNECTOR - A1 MINI** (THIS IS A **MUST-HAVE**—GRAB A COUPLE FROM THE BAMBU STORE).

ONCE YOU HAVE EVERYTHING READY, LET'S GET THESE INSTALLED AND WRAP UP THIS BUILD! 🚀

## INSTALL THE MAGNETS FOR THE EXTERNAL SPOOL TUBE SUPPORT! 🧲 🛠️

DEPENDING ON HOW MANY SUPPORTS YOU'RE INSTALLING, IT'S TIME TO **ATTACH THE MAGNETS** TO THE BACK OF EACH PIECE.

👉 **USE APPLICATOR B** TO SECURELY INSTALL THE MAGNETS IN THEIR DESIGNATED SPOTS.

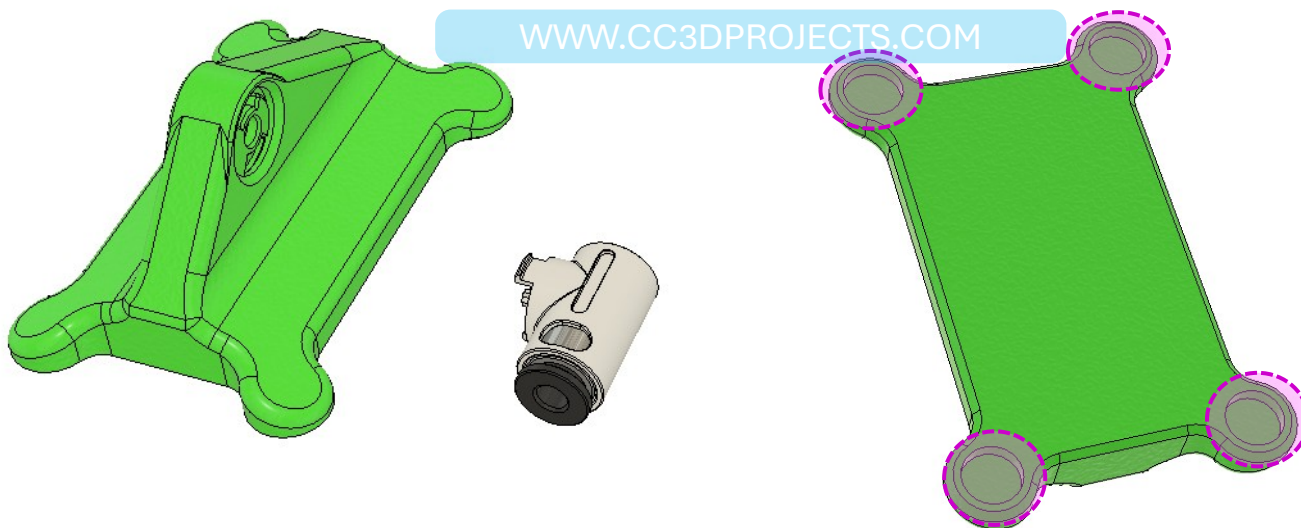



# EXTRENAL SPOOL PTFE TUBE SUPPORT

# ENCLOSURE A1



THE EASIEST STEP—MOUNT THE SUPPORT & YOU'RE DONE! 🎉👉 NOW FOR THE FINAL TOUCH—JUST SNAP THE SUPPORT INTO PLACE WHEREVER YOU PREFER: 👉 RIGHT SIDE, LEFT SIDE, OR BOTH! AND THAT'S IT... YOU'RE FINISHED! 🎉👉 TAKE A STEP BACK, ADMIRE YOUR WORK, AND GET READY FOR SOME NEXT-LEVEL PRINTING! 🖨️👉 THANKS FOR FOLLOWING ALONG—HAPPY PRINTING! 🎉👉

Buy me a coffee



ALL MATERIAL PRODUCED AND PROVIDED HAS BEEN CONCEIVED, AUTHORED AND PRODUCED BY ENRICO MAZZAROL - ALL RIGHTS RESERVED.

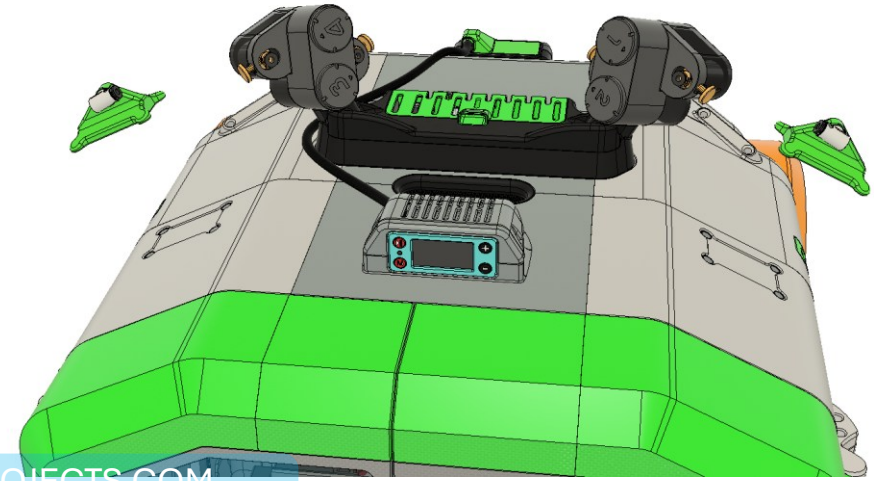
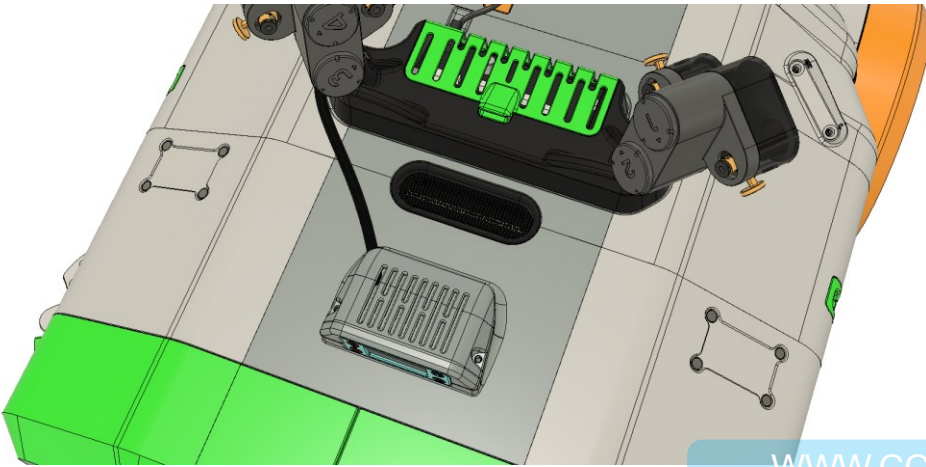

WWW.CC3DPROJECTS.COM

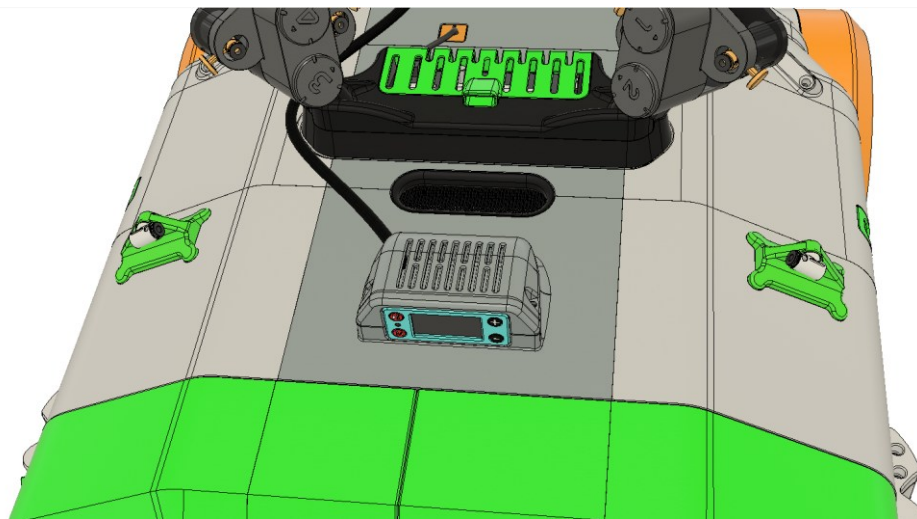



THANKS FOR STICKING WITH ME THROUGH THIS ASSEMBLY GUIDE!  
IT TOOK ME HOURS TO PUT THIS GUIDE TOGETHER, AND I TRULY HOPE IT'S BEEN CLEAR AND EASY TO FOLLOW.  
IF THERE'S ANYTHING THAT WASN'T SUPER CLEAR OR IF YOU FEEL LIKE SOMETHING'S MISSING,  
DON'T HESITATE TO REACH OUT [WWW.CC3DPROJECTS.COM](http://WWW.CC3DPROJECTS.COM)  
I'M ALWAYS HERE TO HELP AND PROVIDE ANY SUPPORT OR CLARIFICATION YOU NEED.

ENJOY YOUR NEW FEATURE!

CIAO!!  
!

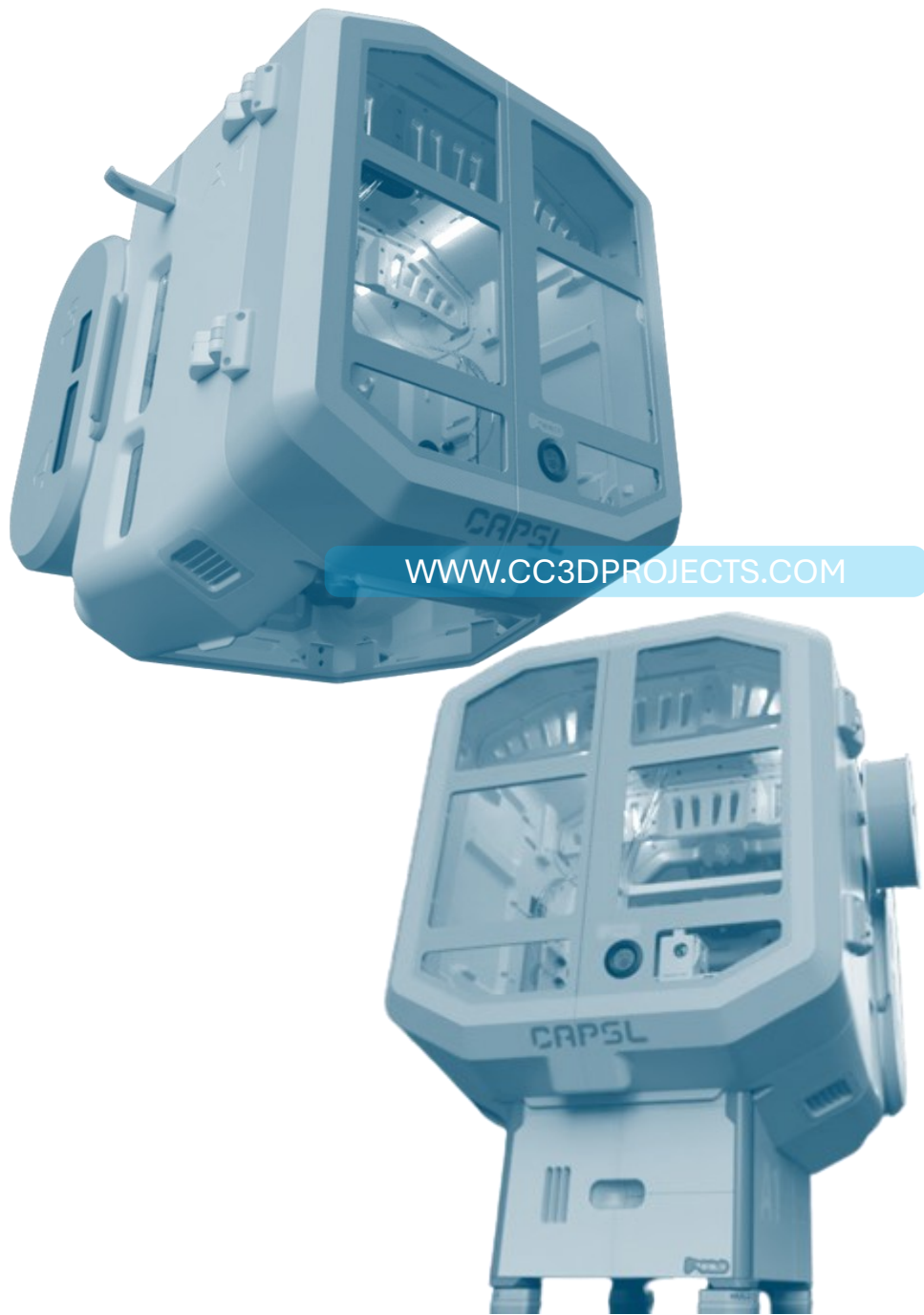

WWW.CC3DPROJECTS.COM

© 2025 CC3DPROJECTS. ALL RIGHTS RESERVED.

THIS MANUAL IS PROTECTED BY COPYRIGHT LAW AND MAY NOT BE REPRODUCED, DISTRIBUTED, OR USED IN WHOLE OR IN PART WITHOUT THE WRITTEN PERMISSION OF THE AUTHOR OR PUBLISHER. ANY VIOLATION WILL BE PROSECUTED TO THE FULLEST EXTENT OF THE LAW.

THE ENCLOSURE A1 AND ALL ITS COMPONENTS, INCLUDING BUT NOT LIMITED TO DESIGNS, SCHEMATICS, ASSEMBLY INSTRUCTIONS, AND PHOTOGRAPHS, ARE THE EXCLUSIVE PROPERTY OF ENRICO MAZZAROL AND ARE PROTECTED BY COPYRIGHT LAW AND OTHER INTELLECTUAL PROPERTY LAWS.

COPYING, DISTRIBUTING, MODIFYING, REPRODUCING, TRANSMITTING, OR USING THE HDRI SYSTEM IN ANY FORM WITHOUT THE WRITTEN PERMISSION OF CC3DPROJECTS IS PROHIBITED.

FOR USAGE REQUESTS, PERMISSIONS, OR OTHER INQUIRIES, PLEASE CONTACT [CC3DPROJECT@GMAIL.COM](mailto:CC3DPROJECT@GMAIL.COM).